

# 13th AEC AIR CLEANING CONFERENCE

## SESSION II

### PERFORMANCE OF AIR CLEANING SYSTEMS

Monday, August 12, 1974

CHAIRMAN: Peter A. Morris

#### PERFORMANCE OF AIR CLEANING SYSTEMS IN NUCLEAR FACILITIES

D.W. Moeller

#### RELIABILITY AND TESTING CONSIDERATIONS IN THE DESIGN OF NUCLEAR REACTOR FILTRATION SYSTEMS

A. O'Nan, R.P. Williams,  
J.M. Goldsmith

#### THE AEC REGULATORY VIEW OF THE RELIABILITY OF AIR CLEANING SYSTEMS IN NUCLEAR FACILITIES

R. Bellamy, R. Zavadoski

#### THE USER'S VIEW OF THE RELIABILITY OF AIR CLEANING SYSTEMS IN NUCLEAR FACILITIES

J.L. Kovach

#### OPENING REMARKS OF SESSION CHAIRMAN:

The name of this session is the Performance of Air Cleaning Systems. Three of the four papers have the word "reliability" in the title, so I think that is really the theme of the session. Since it is, I'd like to say a word or two about reliability. I think the definition most often used, at least in the nuclear business, is that reliability is the probability of performing the intended function when called upon. In my own Office of Operation Evaluation, we have now developed a system for collecting experience information, and for digesting those things which are required to be reported by reactor licenses. They are presently labeled Abnormal Occurrence Reports. An Abnormal Occurrence is a compromise between an "incident" and an "event". Maybe it's not a good choice of terms, but that's what they are called, Abnormal Occurrences. They may or may not have any safety significance, but they do relate to performance. From approximately 45 nuclear power plants in operation today, we are receiving roughly 80 to 100 Abnormal Occurrence reports each month. With the flow of information becoming so great, we need modern techniques to handle the information. We have developed an abstracting system which puts the abstracts in the computer and then allows us to sort them according to any field of information provided. It's from this file of Abnormal Occurrence reports that Dade Moeller developed his paper. I call this file an "event oriented consequence" body of information. It's not reliability-type information in the usual sense of statistics, but it's related to the significance of what's

## 13th AEC AIR CLEANING CONFERENCE

taking place. I made a computer run just before I left today and we now have some 63 events of abnormal occurrences of off-gas systems since 1969, so it certainly is an interesting topic. More related to reliability, is the hardware oriented systems, or statistics systems, being put into operation as of July of this year under the sponsorship of the American Nuclear Society-N 18.20 "Program for Collection of Reliability Data in Nuclear Power Plants" (also called the nuclear reliability data system). This system will begin using computer techniques for storing information on pedigree-type basic engineering data relating to components and systems that are being followed in operation in nuclear plants. I anticipate there will be three or four thousand items in each plant about which we will collect information on successful operations as well as failures. Then, one can do his own manipulation of statistics to arrive at failure rates, and so on. It's in this context that I'm interested in reliability. And, of course, off-gas systems are a very important part of reliability.

Our first author is Dade W. Moeller, who will talk about the performance of air cleaning devices in operational nuclear facilities.

# 13th AEC AIR CLEANING CONFERENCE

## PERFORMANCE OF AIR CLEANING SYSTEMS IN NUCLEAR FACILITIES

Dade W. Moeller  
Harvard Air Cleaning Laboratory  
Harvard School of Public Health  
Boston, Massachusetts

### Abstract

A review of published reports of failures in air cleaning and airborne waste management systems at nuclear installations over the past several years indicates instances of disruption of noble gas adsorption systems due to hydrogen explosions, decreased performance of particulate filters due to the presence of contaminants or the failure of seals and damper controls, and improper evaluation of the efficiency of air cleaning systems due to sampling and other procedural errors. Included in this paper is a tabulation of the major abnormal events reported to have occurred in air cleaning systems since 1966, and an assessment of these events in terms of their implications to air cleaning specialists. Although a small portion of the reported failures can be attributed to manufacturing and design defects, a major share appear to be due to errors on the part of the people responsible for the operation and maintenance of this equipment.

### I. Introduction

Properly designed and operated air cleaning and airborne waste management systems are assuming increasing importance in the nuclear industry. For some time, such systems have been an integral part of the engineered safeguards for the confinement of airborne particulates and gases following an accident or emergency situation. With the promulgation of the "As Low As Practicable" (ALAP) criterion,<sup>(1)</sup> air cleaning and airborne waste management systems have become an essential part of effluent control procedures during normal operations.

Under either accident situations or routine operations, efficient and dependable performance of air cleaning systems is essential if release limits are to be met. In this paper, it is our purpose to review some of the problem areas noted in these systems in the past and to comment upon recent changes which are having a major impact on the design and operation of such systems.

### II. Review of Failures in Air Cleaning Systems

Operation of air cleaning and airborne waste management systems outside the limits prescribed in the Technical Specifications for a given nuclear facility requires the submission of an explanatory report to the AEC Regulatory Staff. Each such report is recorded as an "abnormal event" and tabulations of all such events from 1966 to the present time have been prepared and published.<sup>(2-8)</sup>

## 13th AEC AIR CLEANING CONFERENCE

### A. Categories of Failures

A review of the reported information shows that abnormal events in air cleaning systems can be grouped into the seven categories outlined below. A selection of examples illustrating the types of events occurring within each of these categories is given in Table I.

#### 1. Fires and Explosions

Data show that there has been a variety of fires and explosions during recent years in air cleaning and ventilation systems, particularly those associated with the control of off-gases from nuclear power reactors. Although a limited number of these events have been caused by ignition sources such as welding torches, electrical shorts, and, possibly, lightning accompanying electrical storms, the cause of some of them is yet to be determined. Measures currently being explored to avoid such events in the future include better electrical grounding of filters and increased purging to reduce the concentrations of explosive gases in such systems.

#### 2. Filter Failures Due to Contamination

Data show that contamination of adsorption and filtration systems by foreign materials such as moisture, acid, and lubricating oil is common. Failures can be attributed to a variety of causes ranging from installation of non-acid resistant filters in an acid atmosphere to failure to open condensation drain lines to prevent moisture accumulation within such systems. In the main, it appears that the vast majority of these occurrences are a direct result of improper procedures on the part of maintenance personnel. Whereas fires and explosions in air cleaning systems appear to be a problem occurring primarily at nuclear reactor installations (particularly in recent years), filter failures due to contamination by foreign materials appear not to be limited to any single type of nuclear facility.

#### 3. Failures Due to Mechanical Damage, Excessive Pressure and Other Causes

A review of the published data reveals that filter ruptures due to improper handling and installation by maintenance personnel are the source of numerous abnormal events in nuclear installations. This is particularly the case in chemical processing plants where failure of an air cleaning system can result in large releases of airborne radionuclides to the environment. With the planned startup of two additional commercial chemical processing plants within the next few years, it will be interesting to see if such incidents continue.

4. Plugged Filters

The problem of plugged filters appears to be primarily associated with the operation of glove boxes and laboratory hoods. As a result, the majority of abnormal events involving this type of filter problem during the past several years have been confined to fuel handling facilities. With the planned institution of the recycling of plutonium as a fuel in power reactors within the next few years, this particular problem could represent an area of increasing concern in air cleaning operations.

5. Failures of Gaskets and Seals

In terms of reportable abnormal events, the failure of gaskets and seals in components of air cleaning systems does not appear to be a major problem. Although there was one reported incident in 1968, when an organic binder failed because of radiation damage, this type of failure has not been repeated.

6. Design and Operator Errors

As may be noted from the tabulated data, there has been a variety of failures of air cleaning systems due to design and operator errors. These range from improper operation of valves so that airborne radionuclides are directed to the wrong place, to failure to turn on exhaust fans or to close by-pass dampers necessary to make air cleaning systems effective.

Although not recorded in Table I, there has been a multitude of additional errors involving the failure of supporting activities necessary for evaluation of the performance of air cleaning systems. These include the inactivation of stack gas monitors due to blown fuses, inadvertent operation of a gas monitor in the purge mode so that it failed to collect a representative sample, the accumulation of moisture on the filter paper in a particulate detector so that its efficiency was considerably decreased, installation of particulate sampler intake lines of excessive length and with sharp turns and kinked tubing (causing radioactive materials to deposit in the sample lines ahead of the detectors), failure to collect samples at stages representative of conditions within air cleaning systems, and failure to analyze samples which had been collected. Related problems include improper measurement of the differential pressure across HEPA filters, failure to test them in-place, and failure to install ductwork which could withstand the maximum differential pressure expected during accident conditions.

7. Exposures During Handling of Spent Filters

One of the consequences of the implementation of the ALAP criterion is that greater quantities of radioactive material are being handled within waste management systems in nuclear facilities. As a result, exposures of maintenance and operating personnel will be increased unless proper care and planning are

## 13th AEC AIR CLEANING CONFERENCE

exercised. Three examples of excessive exposures which have occurred during the handling of spent filters in the past are listed in the last section of Table I. These cases emphasize the need for those responsible for the design and operation of air cleaning systems to give careful attention to the ease with which spent filters can be removed and transferred into shielded containers for disposal without exceeding permissible exposures.

### B. Analysis of the Reported Data

A review of the data presented in Table I shows that there is much work to be done. Problems due to moisture contamination of filters were reported in 1968 and continue to occur today. The destructive effects of oil on impregnants for capturing methyl iodide in charcoal adsorbers were noted several years ago and this continues to be a problem today, although hopefully at a decreasing rate.

Although a portion of the failures in air cleaning systems can be attributed to manufacturing and design defects, a major share appear to be due to errors on the part of the people responsible for the maintenance and operation of these types of equipment. Admittedly, the sample is small but a review of the approximately forty events cited in Table I, for which the cause was known, shows that twenty-seven (approximately 65%) were directly attributable to human error or inadequate maintenance. Only four events (about 10%) could be attributed to failure of an equipment component. If design errors are counted as human errors, over three quarters of all the events can be attributed to this cause.

Because of the frequency with which improper positioning of valves has caused problems in air cleaning systems, it might be worthy of consideration to have a sign attached to each such valve to indicate the "open" and "closed" position as well as to specify which position is proper for normal operation. Consideration might also be given to providing indicators in the control room, in the case of power reactors, of the positioning of valves and dampers in air cleaning and airborne waste management systems similar to those now provided for key valves in the containment and emergency core cooling systems.

It seems appropriate also to comment on the several reported abnormal events in which a safety assist unit added to an air cleaning system has created a new problem of its own. Notable examples are the electric heaters installed in many systems to keep the filters and charcoal dry which, in turn, have shorted and provided an ignition source for fires in the very systems they were installed to protect.

### III. Recent Developments of Importance to Air Cleaning Systems

For some time, the U. S. Atomic Energy Commission (AEC) has recognized the need for improvements in air cleaning systems as applied in nuclear installations. Design objectives for such

## 13th AEC AIR CLEANING CONFERENCE

systems are specified in Section 50.34a of the Code of Federal Regulations (Title 10, Part 50),<sup>(9)</sup> and Section 50.362 requires the development of Technical Specifications relating to procedures for the installation, maintenance and operation of airborne effluent control equipment. Additional recommendations on the operation of air cleaning systems are being provided through a comprehensive series of Regulatory Guides, also being prepared by the AEC. Examples of Regulatory Guides having an impact in this subject area are listed in Table II.<sup>(10)</sup> Basic to essentially all of these rules, standards, and guides is the "As Low As Practicable" (ALAP) criterion.

### A. The "As Low As Practicable" Criterion

As originally interpreted, the ALAP criterion applied primarily to limitations on liquid and airborne waste releases from nuclear installations. Subsequent to its development, however, this criterion has been extended to essentially all aspects relating to good practice in the design and operation of nuclear facilities. The specific impact of this criterion on air cleaning systems is exemplified by Regulatory Guide 8.8,<sup>(11)</sup> which covers "Information Relevant to Maintaining Occupational Radiation Exposures As Low As Practicable (Nuclear Reactors)." Examples of factors which must be considered in accordance with the recommendations of this Guide are outlined below.

1. Air cleaning systems must be designed for easy access and service so as to keep personnel exposures ALAP during alterations, maintenance, decontamination, and filter changes; wherever practicable, radiation and airborne contamination monitoring equipment with remote readout should be included in areas to which personnel normally have access; sampling sites should be located so as to minimize exposures during routine sample collection operations.

2. The design must be such as to cope as expeditiously as possible with fires, spills, equipment failure and other types of accidents; precautions should be provided to minimize the spread of contamination and to facilitate decontamination; all features for radiation control should be designed to accommodate maximum expected failures.

3. Remote handling equipment and movable portable shielding should be provided wherever needed and practicable; design considerations must take into account methods for the final disposal of spent filters.

4. Associated personnel must be well-trained and qualified; they must be familiar with techniques for minimizing airborne contamination by proper use of ventilation systems; they must know to purge areas before entering; they must be able to plan operations so as to perform tasks with the fewest people in the least practicable time.

## 13th AEC AIR CLEANING CONFERENCE

### B. Other Considerations

In addition to the examples cited above, the ALAP criterion has had an impact in other areas relating to air cleaning systems. Furthermore, there have been changes with respect to the philosophy of the operation of nuclear facilities which are influencing air cleaning practices. Examples of these developments are given below.

#### 1. Multi-unit Nuclear Power Stations

Electric power generating stations consisting of as many as four nuclear reactor units are being built today and stations with six units are in the planning stages. Under the ALAP criterion, population dose rate limits permitted as a result of radionuclide releases under routine conditions are essentially the same regardless of the number of units comprising a given electric power station. As a result, air cleaning specialists are being called upon to design and operate systems at efficiencies far above those previously required.

#### 2. Discontinuation of Tall Stacks

In the past, nuclear power reactor facilities were equipped with tall stacks for the dispersion of airborne effluents. On newer facilities today, such stacks have been replaced by vents and the atmospheric dispersion in the immediate vicinity of the plant is far reduced over that previously available. Since lower vents result in greater dose rates at the plant boundary for a given effluent release, this situation is placing far greater demands on airborne effluent control systems.

#### 3. Relative Importance of Various Sources

In past years, air ejectors were one of the principal sources of airborne effluents from Boiling Water Reactors. Subsequent control of this source, under the ALAP requirement, has increased the importance of the control of other formerly less important sources, such as containment purges, condenser blowdown gases, and vented gases from liquid waste tanks. As a result, those in charge of airborne cleanup systems must now take into account the design and operation of more systems for the control of a greater number and variety of sources. This same situation has also brought about the need for greater reliability within such systems. Where the requirements for greater reliability are being met through installation of redundant components, questions have arisen as to whether it is better to have the extra units in parallel or in series, and what the proper cut-off point is with respect to the addition of multiple cleanup units in series. A further complication is that evaluations of the efficiency of multiple units in series are often beyond the ability of current testing methods.



## 13th AEC AIR CLEANING CONFERENCE

As a result, a need has arisen either for new methods of testing, or for the maintenance of design requirements so that components within such systems can be tested on an individual basis.

### 4. Modernizing of Older Plants

When older nuclear facilities fail to meet the ALAP criterion, it has become common practice to require backfitting with more modern air cleaning systems. In some cases, upgrading of such systems can be accomplished through modifications of existing equipment; in other cases, it requires the installation of completely new systems. In either instance, such practices are increasing the demands for services from air cleaning specialists and frequently require the utmost in design ingenuity to accomplish the task with the minimum of disruption and expense to those responsible for the operation of the plant.

### 5. Zero Liquid Release Systems

Certain of the newer Pressurized Water Reactors are being designed so that, under normal conditions, radioactive liquid wastes will not be released to the environment. Instead, such wastes will be processed through treatment units and re-used within the plant. One of the consequences of this practice is that there is a gradual buildup of radionuclides such as tritium in liquids within the plant. This, in turn, can lead to increased radiation exposures to operating personnel, increased difficulties in plant maintenance, and increased population doses in case of accidental releases of such liquids to the environment.

One of the primary sources of increased exposures to plant personnel is from tritium which can become airborne through evaporation from the various liquids being recycled. This places greater demands on plant ventilation systems for providing personnel protection. Where tritium concentrations must be reduced, one approach is to evaporate liquid wastes and release them to the atmosphere. This again places greater burdens on air cleanup and atmospheric dispersion systems.

### 6. Air Cleaning Systems as an Engineered Safeguard

Today, with the construction of greater numbers of nuclear power reactors with higher power levels, air cleaning systems are becoming an increasingly important component of the engineered safeguards being incorporated into nuclear facility design. In certain reactors, such as those at the Savannah River Plant, air cleaning systems are being evaluated as a possible substitute for physical containment. In many nuclear power plants, safe occupancy of the reactor control room following a postulated accident is dependent upon the performance of air cleaning systems. In these circumstances,

## 13th AEC AIR CLEANING CONFERENCE

such systems must be designed to provide protection against airborne releases within the plant as well as from hazardous products accidentally discharged into the atmosphere from industrial facilities within the vicinity of the plant. Furthermore, to meet the requirement that they function following an accident, air cleaning systems at many nuclear power installations must be provided with emergency sources of power and must be shown to be capable of continuing to operate following an earthquake, tornado, or explosion. These and other requirements are increasing both the breadth and depth of the challenges being faced by air cleaning specialists.

### 7. The Dose Commitment Concept

In recent months, there has been increasing acceptance of the dose commitment concept<sup>(12)</sup> as a useful tool for evaluation of the long range impact of environmental radionuclide releases. The objective of this concept is to take into consideration the dose which the population will receive due to the presence within the environment of long-lived radionuclides which have accumulated over a period of time from past releases from nuclear facilities. It is conceivable, for example, that if releases are not properly controlled, environmental concentrations of long-lived radionuclides, such as plutonium-239 and iodine-129, could build up to the point that the resulting dose rates to the population would exceed the dose limits even if further releases were prohibited. On a shorter range basis, the same problem might exist with respect to radionuclides such as krypton-85 and tritium.

From the standpoint of air cleaning operations, evaluation of environmental releases on this basis could lead to reductions in acceptable discharge limits. This, in turn, could lead to more stringent removal requirements. In addition, this concept places increased emphasis on the establishment of safe methods for the disposal of air cleaning components containing significant concentrations of long-lived radionuclides.

### 8. Conservation of Energy

One additional item which may have an impact on the design, installation, and operation of nuclear air cleaning systems is the energy conservation movement which developed as a result of the "energy crisis" experienced during the past winter. As part of the overall assessment of our energy needs, attention has been directed to the possibility of employing greater recirculation of exhaust air within ventilation systems. Inasmuch as this approach can result in significant reductions in energy requirements, it is anticipated that it will be increasingly proposed for nuclear facilities. Any such applications that result in exposures of workers to recycled air will place severe requirements on the reliability and performance efficiency of air cleaning systems.

## 13th AEC AIR CLEANING CONFERENCE

### IV. Summary and Commentary

This review of reports of failures in air cleaning and airborne waste management systems over the past several years indicates instances of the disruption of noble gas adsorption systems due to hydrogen explosions; decreased performance of particulate filters due to the presence of contaminants or the failure of seals and damper controls; and improper evaluation of the efficiency of air cleaning systems due to sampling and other procedural errors. In over 75% of the abnormal events reported during this period the cause was directly attributable to errors in the design or operation of the systems.

Concurrent with these problems, there are a number of developments with respect to the philosophy of the design and operation of nuclear facilities that are placing even more stringent requirements upon air cleaning and airborne waste management systems. This combination of events clearly points out the need for correction of the deficiencies noted and for maintenance of the highest levels of performance within such operations.

Although events due to human error are difficult to control, the major hope for improvement is through the dissemination of information on such events to the widest possible audience within the shortest possible time. The staffs of the Nuclear Safety Information Center and the AEC Directorate of Regulatory Operations are to be complimented for developing the current program for reporting and tabulating abnormal events on a systematic basis. Now that the system has been developed, greater effort needs to be directed to the dissemination and application of the lessons to be learned from the collected data. Those attending this Conference are encouraged to keep abreast of such information, to see that it is applied in their air cleaning activities, and to take time to offer suggestions for possible improvements in this program. Undoubtedly, for example, beneficial changes could be made in the nature of the data reported on abnormal occurrences involving air cleaning systems. Perhaps it would also be helpful if a mechanism could be established through which air cleaning specialists could be sent promptly to a site to analyze given occurrences and to make recommendations for preventing repetitions of the event at that site as well as at others.

Finally, one might ask whether a program such as this would be equally beneficial in the evaluation of airborne and liquid waste control systems in the many industrial applications coming under the jurisdiction of the Environmental Protection Agency. If the answer is "yes" and a similar program could be instituted there, it would be one more example in which those working in the nuclear field have shown the leadership which has come to be expected of people such as yourselves.

## 13th AEC AIR CLEANING CONFERENCE

### References

1. U. S. Atomic Energy Commission, "Public Rulemaking Hearing on: Numerical Guides for Design Objectives and Limiting Conditions for Operation to Meet the Criterion 'As Low As Practicable' for Radioactive Material in Light-Water-Cooled Nuclear Power Reactors," Concluding Statement of Position of the Regulatory Staff, Docket No. RM-50-2 (February 20, 1974).
2. Cramer, E. N., "Safety-Related Occurrences in Reactor and Radioactivity-Handling Operations as Reported in 1966," Nuclear Safety, Vol. 9, No. 3, pp. 249-266 (May-June, 1968).
3. Cramer, E. N. and Casto, W. R., "Safety-Related Occurrences in Nuclear Facilities as Reported in 1967 and 1968," USAEC Report ORNL-NSIC-69 (July, 1970).
4. Scott, R. L. and Casto, W. R., "Safety-Related Occurrences in Nuclear Facilities as Reported in 1969," USAEC Report ORNL-NSIC-87 (August, 1971).
5. Scott, R. L., "Safety-Related Occurrences in Nuclear Facilities as Reported in 1970," USAEC Report ORNL-NSIC-91 (December, 1971).
6. Scott, R. L. and Gallaher, R. B., "Safety-Related Occurrences in Nuclear Facilities as Reported in 1971," USAEC Report ORNL-NSIC-106 (September, 1972).
7. Scott, R. L. and Gallaher, R. B., "Safety-Related Occurrences in Nuclear Facilities as Reported in 1972," USAEC Report ORNL-NSIC-109 (December, 1973).
8. Thompson, Dudley, Boyle, E. L., and Grosman, L. H., "Summary of Abnormal Occurrences Reported to the Atomic Energy Commission During 1973," Report OOE-OS-001, Office of Operations Evaluation, Directorate of Regulatory Operations, U. S. Atomic Energy Commission, Washington, D. C. (May, 1974).
9. U. S. Atomic Energy Commission, "Code of Federal Regulations, Title 10, Part 50," Washington, D. C.
10. "USAEC Regulatory Guide Series," Directorate of Regulatory Standards, U. S. Atomic Energy Commission, Washington, D. C.
11. U. S. Atomic Energy Commission, "Information Relevant to Maintaining Occupational Radiation Exposure As Low As Practicable (Nuclear Reactors)," Regulatory Guide 8.8, Directorate of Regulatory Standards, Washington, D. C. (July, 1973).
12. U. S. Environmental Protection Agency, "Environmental Radiation Dose Commitment: An Application to the Nuclear Power Industry," Office of Radiation Programs, Report EPA-520/4-73-002, Washington, D. C. (February, 1974).

13th AEC AIR CLEANING CONFERENCE

TABLE I  
 REPORTED ABNORMAL EVENTS IN NUCLEAR AIR CLEANING SYSTEMS  
 (1966 - 1974)

<u>Nature of Problem</u>	<u>Facility Involved</u>	<u>Year of Occurrence</u>	<u>Cause of Problem</u>	<u>Exposure Involved</u>	<u>Corrective Action</u>
FIRES AND EXPLOSIONS					
Fire in particulate and halogen filter	Research Reactor	1969	Mechanic used torch to remove corroded cover bolts on filter	None	Instigated new administrative procedures
Fire in charcoal filters in standby gas treatment system	Power Reactor	1972	Electrical short in heater	Unknown	Corrected wiring deficiency
Fire in Ventilation System	Fuel Handling Facility	1972	Organic contaminants in fiber glass fire resistant ductwork	None	Replaced ductwork with non-flammable materials
Explosion in off-gas system	Power Reactor	1971	Gases in pipe ignited by acetylene welding torch	Minimal (plant was shutdown)	Repair procedures altered
Explosion in off-gas system	Power Reactor	1971	Ignition of radiolytic hydrogen and oxygen in holdup system; cause unknown	Release not monitored	Unknown

13th AEC AIR CLEANING CONFERENCE

<u>Nature of Problem</u>	<u>Facility Involved</u>	<u>Year of Occurrence</u>	<u>Cause of Problem</u>	<u>Exposure Involved</u>	<u>Corrective Action</u>
Explosion in main condenser off-gas system	Power Reactor	1972	Ignition of gases by electric preheater coil	Unknown	Unknown
Explosion in temporary filter during purge of off-gas piping	Power Reactor	1973	Ignition caused by welding torch	Unknown	Unknown
Explosion in off-gas holdup system	Power Reactor	1973 (several occurrences)	Probably due to lightning	Some release of radioactive material to atmosphere	Redesign of system
Explosion in off-gas holdup system	Power Reactor	1973 (several occurrences)	Cause unknown (no electrical storms in the area)	Some release of radioactive material to atmosphere	Introduced continuous air purge to system
Explosion in off-gas holdup system	Power Reactor	1974	Unknown (possibly electrostatic discharge)	Some release but was within Technical Specifications	Improved electrical grounding of filters
FILTER FAILURE DUE TO CONTAMINATION WITH MOISTURE, ACID, OIL OR OTHER MATERIAL					
Oil on Charcoal Filters	Power Reactor	1966	Oxidized lubricating oil entered air-flow	Unknown	Unknown
Moisture on Filter	Chemical Processing Plant	1968	Moisture weakened plywood casing	Unknown	Unknown

13th AEC AIR CLEANING CONFERENCE

<u>Nature of Problem</u>	<u>Facility Involved</u>	<u>Year of Occurrence</u>	<u>Cause of Problem</u>	<u>Exposure Involved</u>	<u>Corrective Action</u>
Moisture on Filter	Radio-nuclide Research Laboratory	1969	Water becoming airborne during underwater unloading of shipping cask	3 $\mu$ Ci $^{192}$ Ir released to atmosphere	Change in procedures
Moisture damage to filters	Fuel Handling Facility	1970	Unknown	67 $\mu$ Ci of Pu released to atmosphere	Replace filter
Moisture and acid damage to filter	Fuel Handling Facility	1970	Moisture and acids gained access to exhaust duct	40 to 750 MPC-HRS	Alterations made to prevent recurrence
Acid on HEPA Filter	Fuel Handling Facility	1972	Non-acid resistant filters installed in error	No excessive contamination	Install correct filters
Moisture on HEPA Filter	Power Reactor	1973	Condensation drain line left closed	Unknown	Improved administrative procedures
Acid contamination of charcoal filters	Power Reactor	1974	Dry boric acid gained access to air circulation fan and was carried to the filters	Unknown (filter efficiency degraded)	Filters to be re-placed

FILTER FAILURES DUE TO MECHANICAL DAMAGE, EXCESSIVE PRESSURE, AND/OR OTHER CAUSES

Filter failure	Fuel Handling Facility	1967	Filter rupture (cause unknown)	$\sim$ 1 gram $^{235}$ U released to atmosphere	Replace filter
----------------	------------------------	------	--------------------------------	---	----------------

13th AEC AIR CLEANING CONFERENCE

<u>Nature of Problem</u>	<u>Facility Involved</u>	<u>Year of Occurrence</u>	<u>Cause of Problem</u>	<u>Exposure Involved</u>	<u>Corrective Action</u>
Failure of high-efficiency glass wool filters	Chemical Processing Plant	1967	Excessive pressure drop across filters	Unknown	Unknown
Filter failure	Chemical Processing Plant	1968	Filter rupture (cause unknown)	one day release equal to monthly allowable	Replace filter
Failure of main ventilation filter bank (some parts left exhaust duct and fell onto building roof)	Chemical Processing Plant	1968	Over-pressure of ventilation system	Eleven times monthly allowable activity released to atmosphere	Reduced high pressure drop filter alarm
Filter failure on gas treatment system	Power Reactor	1971	Two filters damaged by grinding or burning torch during modification of air heater	Unknown	Replace filters and patch sealant
Filter failure	Fuel Handling Facility	1972	Rupture of HEPA filter (cause unknown)	0.24 gram <sup>235</sup> U released to atmosphere from stack	Replace filter
PLUGGED FILTERS					
Hood	Fuel Handling Facility	1966	Inadequate maintenance	1 person 1.6 x MPC <sup>235</sup> U	Replace filter; improve maintenance



13th AEC AIR CLEANING CONFERENCE

<u>Nature of Problem</u>	<u>Facility Involved</u>	<u>Year of Occurrence</u>	<u>Cause of Problem</u>	<u>Exposure Involved</u>	<u>Corrective Action</u>
Hood	Fuel Handling Facility	1970	Non-functioning manometer failed to warn operator	1 person 44 MPC-HRS to airborne uranium	Repaired manometer
Hood	Fuel Handling Facility	1971	Inadequate maintenance	1 person 1.05 MPC	Install air-flow gauge
Glove Box	Fuel Handling Facility	1968	Inadequate maintenance	None	Replace filter
Glove Box	Fuel Handling Facility	1970	Operator error and inadequate maintenance	1 person 58 MPC-HRS of insoluble uranium	Keep window closed and better checks on pressure
Glove Box	Fuel Handling Facility	1971	Inadequate maintenance	22 persons	Install pressure alarm
Dissolver Loading Box	Fuel Handling Facility	1972	Inadequate maintenance	1 person 45 MPC-HRS airborne uranium	Replace filter

FAILURES OF GASKETS OR SEALS

Reduced radio-iodine filter removal efficiency	Power Reactor	1966	Poor gasket sealing	Unknown	Institute improved gasket sealing procedures
--	---------------	------	---------------------	---------	--

13th AEC AIR CLEANING CONFERENCE

<u>Nature of Problem</u>	<u>Facility Involved</u>	<u>Year Occurrence</u>	<u>Cause of Problem</u>	<u>Exposure Involved</u>	<u>Corrective Action</u>
Glass fiber filter media became porous with cracks	Chemical Processing Plant	1968	Organic binder failed due to radiation damage permitting filter vibration	Allowable monthly airborne release occurred within 3 days	Replace filters
DESIGN AND OPERATOR ERRORS					
Radio-active gases from reactor discharged to atmosphere	Research Reactor	1966	Ventilation valve left open	Less than 10CFR20	New Administrative Procedures
Off-gases directed into containment building instead of to exhaust stack	Power Reactor	1966	Ventilation damper closed as part of accident response sequence	Unknown	Design of system altered
Lack of airflow through hood	Fuel Handling Facility	1969	Exhaust fans not turned on	2 people 0.0008 $\mu$ Ci lung burden of enriched uranium	Blower now programmed to operate continuously
Over-pressure in glove-box	Fuel Handling Facility	1970	Nitrogen purge allowed to continue to operate during change of primary HEPA filter	25 people 900 MPC-HRS over an 8 hour period	New Administrative Procedures

13th AEC AIR CLEANING CONFERENCE

<u>Nature of Problem</u>	<u>Facility Involved</u>	<u>Year Occurrence</u>	<u>Cause of Problem</u>	<u>Exposure Involved</u>	<u>Corrective Action</u>
Lack of airflow in hood	Radio-nuclide Research Laboratory	1972	Improper electrical connections caused exhaust fan to rotate in wrong direction	Unknown	Electrical wiring corrected
Off-gas filter assembly by-passed	Power Reactor	1973	By-pass valve left open following replacement of filters	Unknown	Improved administrative procedures
Standby gas treatment system inoperable	Power Reactor	1973	Damper closed due to defect in motor operated discharge damper linkage	None	Repaired damper linkage

EXCESSIVE EXPOSURES DURING HANDLING OF CONTAMINATED FILTERS

Excessive personnel exposure during removal of a collapsed dissolver off-gas filter	Chemical Processing Plant	1968	Reason for collapse of filter unknown	1 person 3.27 rems	Install a downstream support so filters can be placed in a shielded removal cask as a unit
Excessive personnel exposure during handling of contaminated filter	Chemical Processing Plant	1971	Design error in cask liner caused filter to drop to the floor	1 person skin exposure of 6.1 rems	Cask liner has been redesigned

13th AEC AIR CLEANING CONFERENCE

<u>Nature of Problem</u>	<u>Facility Involved</u>	<u>Year Occurrence</u>	<u>Cause of Problem</u>	<u>Exposure Involved</u>	<u>Corrective Action</u>
Potential exposure during handling of contaminated HEPA filter	Fuel Handling Facility	1972	Filter was dropped due to operator error	None (workers were wearing respirators)	None

# 13th AEC AIR CLEANING CONFERENCE

TABLE II

## REGULATORY GUIDES APPLICABLE TO NUCLEAR AIR CLEANING SYSTEMS

<u>Guide Number</u>	<u>Title</u>
1.7	Control of Combustible Gas Concentrations in Containment Following a Loss of Coolant Accident
1.42	Interim Licensing Policy on as Low as Practicable For Gaseous Radioiodine Releases from Light-Water-Cooled Nuclear Power Reactors
1.52	Design, Testing, and Maintenance Criteria for Atmosphere Cleanup System Air Filtration and Adsorption Units of Light-Water-Cooled Nuclear Power Plants
1.70.2	Additional Information--Air Filtration Systems and Containment Sumps for Nuclear Power Plants
3.2	Efficiency Testing of Air-Cleaning Systems Containing Devices for Removal of Particles
3.12	General Design Guide for Ventilation Systems of Plutonium Processing and Fuel Fabrication Plants
3.20	Process Offgas Systems for Fuel Reprocessing Plants
3.16	General Fire Protection Guide for Plutonium Processing and Fuel Fabrication Plants
8.8	Information Relevant to Maintaining Occupational Radiation Exposure As Low As Practicable (Nuclear Reactors)
(*)	General Design Guide for Process Building Ventilation Systems for Fuel Reprocessing Plants
(*)	Calculation of Releases of Radioactive Materials in Liquid and Gaseous Effluents from Pressurized Water Reactors (PWRs)
(*)	Calculation of Releases of Radioactive Materials in Liquid and Gaseous Effluents from Boiling Water Reactors (BWRs)
(*)	Assumptions Used for Evaluating the Habitability of a Nuclear Power Plant Control Room During a Postulated Toxic Chemical Release

\*Under development

DISCUSSION

KAUFMAN: What criteria are used in order to have an incident classified as an event under your classification system?

MOELLER: Undoubtedly Dr. Morris would be better qualified to comment on that, but, as I understand it, it is simply a violation of technical specifications set down for the operation of the particular plant in which the air cleaning system is located. In order to really have an understanding of the basis upon which the abnormal events are reported you would need to read the technical specifications for each of the several plants. Dr. Morris says that is essentially correct.

MURROW: Is there any idea of collecting information on good operations of equipment: that is, how long it works and how well it works under various circumstances?

MORRIS: That is the basis for the new MPRDS system, the nuclear reliability system. The items, or components, of the system and subsystem that are reported upon, are the choice of the utility. I'm pretty sure it will be safety related. It absolutely does not include a lot of hardware, for example. The waste treatment systems that are important to safety probably would be included.

BURCHSTED: This is a comment, not a question. There has been a lot of concern about the radiation resistance of filters. Indeed, we have included radiation resistance tests in the new military standards. However, one instance in your tabulation (if that's the one I'm thinking of) was not a case of radiation damage but high moisture and acid loadings, coupled with extremely poor design. I think the combination of these problems was what actually caused the failure, rather than radiation.

# 13th AEC AIR CLEANING CONFERENCE

## RELIABILITY AND TESTING CONSIDERATIONS IN THE DESIGN OF NUCLEAR REACTOR FILTRATION SYSTEMS

A. O'Nan, R.P. Williams and J.M. Goldsmith  
American Air Filter Company, Inc.  
Louisville, Kentucky

### ABSTRACT

The high performance standards set by USAEC-DRL Regulatory Guides for nuclear reactor filtration systems pose difficult problems for on-site leakage tests. These problems are compounded by the crowded conditions inside reactor structures, and by the fact that, until recently, little consideration has been given by system designers to the needs of testing. Techniques for coping with testing problems on existing systems, and suggestions for improving the testability of future systems, are given. Test crew safety considerations are discussed, and a pair of easily portable contaminant generators is described.

### 1.0 INTRODUCTION

Mechanical contractor specifications for nuclear power plant filtration systems today almost always call for in-place testing of HEPA filter banks, adsorption units, and the housings containing them. Future specifications will surely continue to have in-place testing requirements. As effort continues to reach "low as practical" release conditions, even more demanding performance standards can be expected. These in turn will require more sophisticated and more reliable test techniques. Some plants now operating, however, and some being installed, did not include in-place testing as a requirement when the filtration systems were planned. As a result, it is quite difficult to test such systems to demonstrate conformity with current Regulatory Guide standards, [Ref 1]. The authors have carried out filter and housing leakage tests on numerous systems in nuclear power plants. These systems were designed by other companies as well as our own, and to specifications provided by several architect-engineer firms and owners. We have reason to believe that they provide an inclusive range of test situations, and illustrations of essentially every misery to which a test crew can be exposed. The sections which follow discuss the problems met in testing these systems, techniques for solving them, and suggestions for ways to avoid them in future designs.

### 2.0 HEPA FILTER TESTING PROBLEMS

#### 2.1 DOP Smoke Distribution

The ideal situation for HEPA filter testing would be an arrangement which provided a uniform smoke concentration upstream of the filter or filter bank. This would be coupled with some means for completely mixing the flow downstream, so that a single point reading upstream and downstream of the filter bank would yield its percent penetration. This ideal situation would provide the average of all effects of gasket filter and frame leaks. References [2] to [6] all recognize that this ideal is never met, and field experience confirms this. Available plenum space or duct runs upstream of filter banks are almost always inadequate for proper mixing or distribution of smoke. Indeed, there may be no plenum at all available for mixing. In some cases, we have been able to achieve a concentration range of  $\pm 20\%$  of average concentration, measured as described in ANSI N101.1. Where this has not been possible, as in HEPA banks located downstream of adsorber banks and coupled to them with minimum space plenums, we have had to resort to 'module' testing. This technique isolates each filter cell by use of a set of temporary 'shrouds'

## 13th AEC AIR CLEANING CONFERENCE

(Figure 1). The upstream shroud channels smoke from a generator to a single cell, with minimal spill-over to adjacent cells. A second shroud downstream inhibits smoke penetrating the filter under test from mixing with air from adjacent, unchallenged filters. Since the upstream shroud is not long enough to guarantee complete mixing of smoke released from a single point, the smoke is forcibly distributed across the duct by a distributor attached directly to the generator (Figure 1). The distributor is made of 25 copper tubes of equal length, to provide 25 equal flow smoke streams. Some condensation or impingement of DOP smoke does occur within the distributor, but the coalesced droplets fall back into the generator.

Downstream, the inadequate mixing of the flow is overcome by using a multi-point sampler (Figure 2). This sampler emphasizes the perimeter of the cells where most leaks (i.e. gasket leaks) have been found to occur. The technique does not guarantee discovery of leaks between filter frames or between frames and housing walls. These are checked by using soap-bubble techniques prior to actual filter cell tests, or by inserting blank-off plates and testing the adjacent plenum as if it were a sealed box [Ref 3].

### 2.2 DOP Smoke Concentration and Filter Loading

The detection sensitivity of available photometers is the major factor determining DOP smoke concentration requirements. The photometer must have the ability to measure a leakage of 0.01% or less, if Regulatory Guide 1.52 requirements are to be met. This means that from 20 to 80 mg/m<sup>3</sup> of DOP smoke must be fed to the filter bank being tested. This is a substantial amount of smoke; Table 1 gives a better idea of the consequences of using this concentration of contaminant. The "DOP Use" shows what amount of DOP must be supplied each minute to provide 80 mg/m<sup>3</sup> concentration. The next three columns show the number of generators of three types needed to produce the smoke. The last column shows the amount of DOP which would accumulate in each filter of a bank during the process of determining the

TABLE 1. DOP Smoke Generator Data  
For Various System Sizes

System ft <sup>3</sup> /min	Flow m <sup>3</sup> /min	DOP Use @80 mg/m <sup>3</sup> g/min	Generator Requirements						DOP Load Per Filter(2) g
			Type No.	A(1) kW(3)	Type No.	B(1) kW	Type No.	C(1) kW	
1000	28	2.3	1	1.1	1	0.6	1	1.0	0.4
4000	118	9.0	4	4.4	2	1.1	1	1.0	1.5
10000	283	23	10	11	4	2.2	1	1.0	3.5
30000	849	68	30	33	11	6.6	1	2.0	10.5
60000	1698	126	60	66	21	13.1	2	4.0	21

(1) Generator types:

A - Royco WA (Six Laskin nozzles operated at 25 psig)(air operated)

B - Testing Machines 'Cloud-Maker' 11-48 (thermal)

C - AAF Type SG731 (thermal)

(2) Weight of DOP smoke captured by each filter in bank during a survey of upstream concentration; concentration measured at each cell for 10 sec

(3) Power to drive air compressors



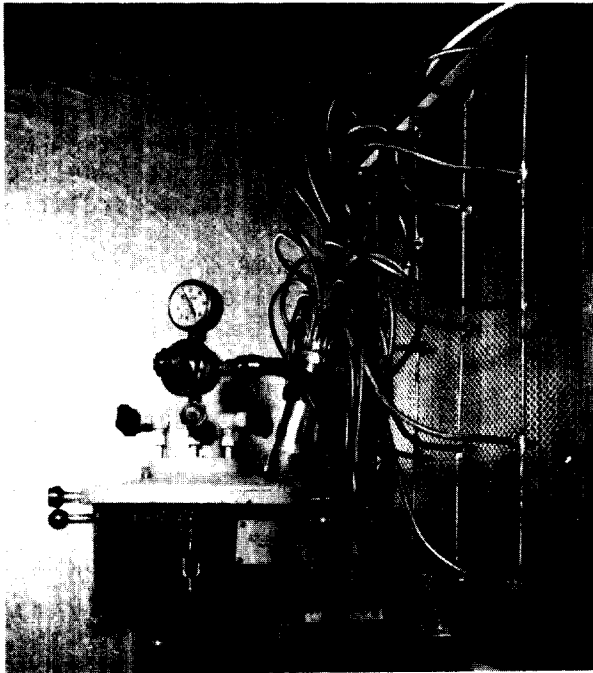

FIGURE 1. DOP Smoke Distributor Mounted in Temporary Shroud



FIGURE 2. Multi-Point Sampling Probe

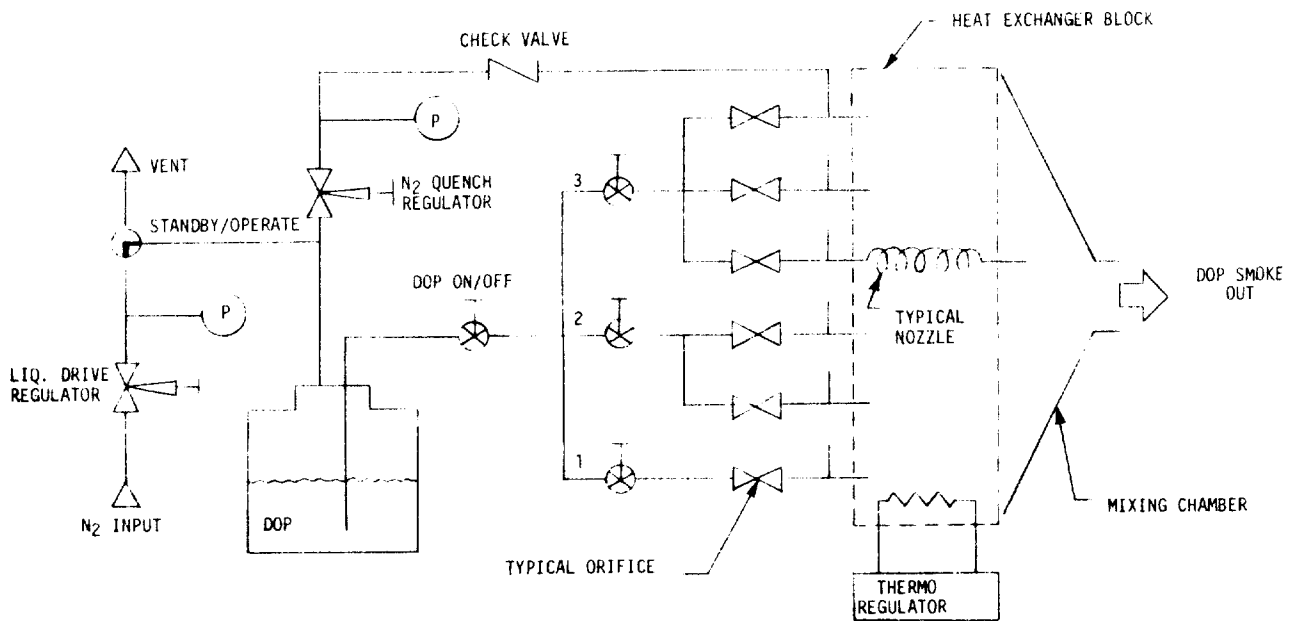

FIGURE 3. Schematic of AAF Portable Thermal DOP Generator

## 13th AEC AIR CLEANING CONFERENCE

distribution of smoke concentration across the bank face. (The time chosen for this calculation is 10 sec/cell, which we consider minimal for such a measurement; some time is required to pump the photometer scattering chamber out and to stabilize on a new concentration.) Several things emerge from this table. First, the flow limit of 30,000 ft<sup>3</sup>/min (849 m<sup>3</sup>/min) for a single filter bank recommended by Regulatory Guide 1.52 is essential, if bank testing is to be used. Second, air-operated DOP generators are pretty impractical for systems above 10,000 ft<sup>3</sup>/min (283 m<sup>3</sup>/min). Compressed-air requirements are simply too great. Third, one had better work very quickly to establish bank concentration in larger flow systems, to minimize filter and personnel exposure to DOP, or else resort to module tests.

### 2.3 Thermal DOP Generator

Thermal DOP Generators generate DOP vapor and then suddenly cool it to cause fine droplet condensation. The standard factory DOP tester (Edgewood Arsenal type Q107) [Ref 7] is of this type, as is the commercially available 'Cloud-Maker'\*. Rolie and Adley described a design in 1971 [Ref 8]. At AAF, we have developed for our own use a unit which is a scaled-up version of the 'Cloud-Maker'. (The similarity of operating principle does not mean that the smokes produced are identical for these generators; they differ somewhat in both mean particle size and particle size distribution. The AAF unit is shown in Figure 3.) Four 500-watt rod type electric heaters are mounted in an aluminum block, surrounding a ring of six spiral passages formed in the block by plugging drilled holes with threaded rod cores. DOP is forced through these spiral passages at the required rate by a simple positive-displacement pumping scheme. Here, DOP is stored in a sealed tank, pressurized with nitrogen to displace the liquid DOP out of the tank at a constant flow rate. The vaporizer block is thermostatted at 320 C, which assures vaporization of the DOP liquid. Additional nitrogen is fed in parallel to the vapor streams to carry the vapor out of the generator. (Nitrogen is essential for this purpose, since the DOP vapor must not come into contact with air before it cools, below its flashpoint.) The output of the generator is so intense that a certain amount of coalescence of droplets takes place at the discharge pipe walls. These are warmed, but cannot be held hot enough to vaporize all coalesced material without starting fires. The balance can be held close enough so that very little or no droplet 'spitting' occurs at the discharge. The generator is very compact, and consumes very little nitrogen in relation to previous designs. Its principal drawback is that in its present form, it does not provide any driving force to convey the smoke through a diffuser system.

### 2.4 Operational Problems in HEPA Testing

The following problems have been met thus far:

Unprotected Filters: Filters without faceguards are sometimes used. Damage is much more likely to such filters than to those provided with faceguards as described in AEC Health & Safety Bulletin 306 [Ref 9]. Faceguards should be provided on both faces; there is almost always some access to both faces and the less visible face is more likely to be damaged without being discovered. Loose Objects: Filter clamp parts, tools, hard hats, belt buckles - all have caused damage to HEPA filters. Filter clamping devices which have no loose elements are preferable to frame or star-type clamps. Test crews must leave wrenches out of their hip pockets. It is very difficult to keep a hard hat on under some duct velocity conditions; brimless, well-strapped hats are needed. Lack of Spares: It

\*Testing Machines, Inc., Amityville, N.Y. 11701

## 13th AEC AIR CLEANING CONFERENCE

is common to find that no spares have been provided to replace filters which cannot be repaired. The cost of hurried replacements, and time lost, makes this a very foolish economy. Approximately 20% of the number of cells in the systems should be available as spares; those not used at one time can be stored for future use.

Concrete Plenum Floors and Walls: These are porous to DOP smoke, even if the most careful (and futile) attempts are made to seal metal housings to them.

Absence of Penetrations for Contaminant Feed and Detection: The normal pattern during testing is to leave some of the equipment outside the tested plenum, taking inside only items which must have short sample-line runs. In some cases, there is too little space to allow any instrumentation inside the plenum. Thus both electrical lines and sampling (or contaminant feed) lines must penetrate plenum walls. In some systems, no provision has been made for this. A simple pipe stub welded to the plenum wall is satisfactory; tape and caulking can be used to seal off lines passing through the stub. However, a coupling might be more desirable, since this connection must be broken repeatedly. It is not desirable to have any specific sealed fittings since test equipment will differ from one test contractor to the next. The penetration must, of course be capped off when testing is finished.

Cold Systems: Some control room systems draw outside air which is still cold, when it reaches the HEPA bank. We observe unusually low concentrations at normal generator settings under these conditions. Wall condensation or coalescence is probably taking place. Little can be done to correct the matter; such systems should be tested on warmer days.

Visual Inspection: Inspection with flashlight and sharp eyes can uncover most leaks and correct them before testing starts. This greatly reduces pollution of cells, and saves time.

### 2.5 Crew Hazards - HEPA Testing

Test crew hazards can be greatly reduced by attention to a few design details. For example:

Catwalks and Ladders: These are often far too skimpy for safe and practical test equipment use. We have made every effort to reduce test equipment weight and bulk; nevertheless, our 'portable' gas chromatograph in its in-plant handling container weighs 90 lb (41 kg) and is 60 X 60 X 45 cm. Reliable testing is not likely to occur when the crew member is hanging from a ladder 10 meters above a solid concrete floor.

Lighting: This is usually woefully inadequate and improperly placed for testing. A flashlight is a dangerous missile, filter mangler, and occupies one half of a man's hands.

Unprotected Fans: A major hazard, easily corrected; both upstream and downstream faces should be protected with coarse wire mesh. We had a near injury where a man had to be dragged out of fan inwash.

Door Slams and Locks: Crews must be constantly aware that these are high pressure-drop systems, and doors will slam shut violently under pressure differentials that exist when the system is at rated flow. There must be means to unlock all doors from both sides - from the inside with no keys or other tools.

Toxicity of Test Contaminants: Gas masks are essential during bank testing. We have no information which attributes long term toxicity to pure DOP; however, it is annoying and nauseating, and no man should take the risk of breathing it in quantity. Gas masks must include both particulate and vapor protection, and elements must be changed frequently.

Electrical Ground Faults: NIOSH requirements and common sense now require that cables be provided with ground fault indicators (GFI) which interrupt power whenever line current imbalance indicates that current leakage to ground has occurred. High quality cables and connectors with proper grounding and shielding must of course be used.

### 3.0 ADSORPTION FILTER TESTING

#### 3.1 Gaseous Contaminant Distribution

### 13th AEC AIR CLEANING CONFERENCE

This is much less of a problem with gaseous contaminants (typically R-112 or R-11 vapor) than with DOP because of the more rapid diffusive mixing of gases. Nevertheless, mixing should be as thorough as possible, with the entrance point located as far upstream as one can get without substantial contaminant loss. Modular testing analogous to that described in Section 2.1 above is sometimes employed; only the distributor and sampler manifolds are different; shrouds are the same. It is not customary to make a survey of upstream concentration distribution, unless no HEPA filter bank is present in the system. The assumption is made [Ref 3] that the distribution variance is no worse for gaseous contaminants than it is for DOP smoke. Such a distribution measurement should be made very quickly to reduce cell pollution.

#### 3.2 Gaseous Contaminant Concentration and Filter Loading

Table 2 lists R-112 usage for various system sizes, together with the load of contaminant captured by each cell of 1000 ft<sup>3</sup>/min (28 m<sup>3</sup>/min) capacity. Loading is based on a 3 min chromatographic test, which is about the time required to run three contaminant feed peaks. Again, 30,000 ft<sup>3</sup>/min (1698 m<sup>3</sup>/min) represents an upper limit of a practical bank test. The contaminant is, of course, stored in the adsorber cells. It will eventually elute out of the cells and either react with surface coatings in the area, be re-adsorbed by other systems, or be exhausted to the atmosphere. Minimal exposure reduces the problems of background pollution during the test. The feed concentration used in Table 2 is typical, being based on practical gas chromatograph sensitivities (about 0.005 ppm of R-112). To meet the Regulatory Guide 1.52 requirement of demonstrated 0.5% penetration, an upstream concentration of 1 ppm is needed. However, the 0.005 ppm sensitivity is a limit, and it is practical to feed 10 ppm.

TABLE 2. R-112 Vapor Loadings and Consumption  
For Various System Sizes

System Flow ft <sup>3</sup> /min	Flow m <sup>3</sup> /min	R-112 Use @ 10 ppm g/min	R-112 Loading per Module (1) g	R-112 Release for Entire Bank (1) g
1000	28	2.4	9.5	9.5
4000	118	9.5	9.5	38
10000	283	23.7	9.5	95
30000	849	71.0	9.5	284
60000	1689	142.0	9.5	568

(1) Assumes exposure of entire bank during testing, with a 4 min chromatographic reading at a single downstream point.

#### 3.3 Gas Contaminant Generation and Detection (R-112)

Again, the generator requirements for bank testing are not trivial. To meet these needs, we have developed a compact generator having only a single control: a thermoregulator. It is shown schematically in Figure 4, and in the photograph, Figure 5. The generator consists of a sealed boiler whose temperature is carefully regulated. The set temperature establishes the vapor pressure of R-112 in the upper part of the chamber; this also establishes the density of R-112 vapor in the head space. A set of nozzles with individual valves is connected in paral-

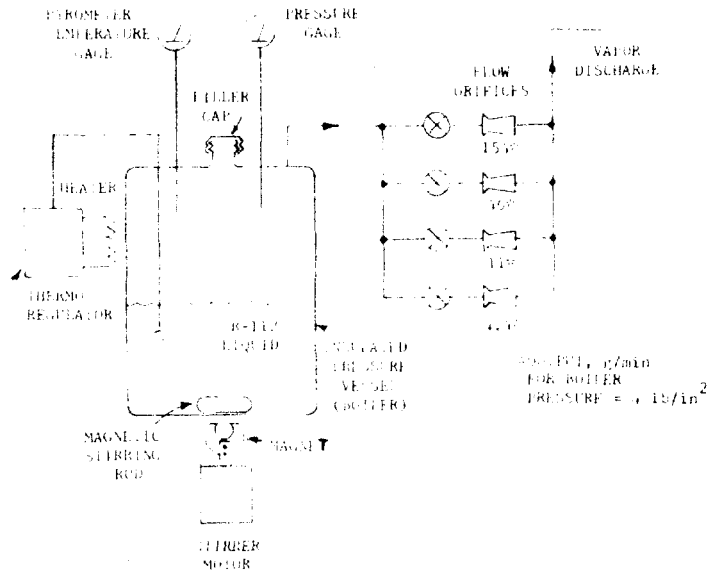

FIGURE 4. Schematic of AAF High Output R-112 Vapor Generator

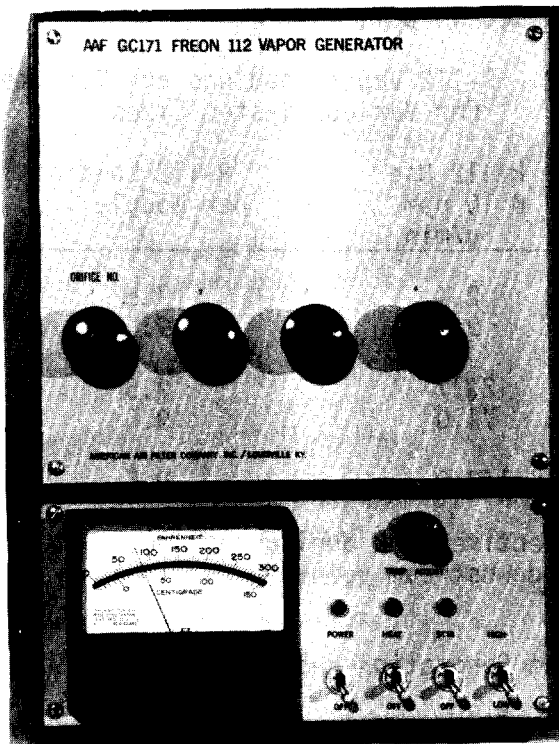

FIGURE 5. R-112 Vapor Generator

## 13th AEC AIR CLEANING CONFERENCE

1el in the discharge pipe. The mass flow from the generator is determined completely by the boiler temperature and the size of the nozzle of nozzles chosen. In operation, the generator boiler is maintained at a fixed temperature, and various size orifices are valved into the discharge line. Feed rate is established by weighing the boiler, before and after calibration runs. There is always some loss of contaminant between generator and duct face, and where no other means of determining concentration distribution exists, there is need to measure upstream concentration. The chromatograph cannot accept the full upstream concentration; a "splitter" is needed. This is incorporated in the device shown schematically in Figure 6, and in the photograph, Figure 7. In addition, this device incorporates a calibrator. The sensitivity of the gas chromatograph detector decays slowly with use, and columns sometimes become polluted. For this reason, AAF makes a calibration run on a chromatograph whenever detector standing current drops by more than 10%. The calibrator provides continuous dispersions of R-112 in air in concentration ranges of 0.001 to 1 ppm ( $8.4 \times 10^{-9}$  to  $8.4 \times 10^{-6}$   $\mu\text{g}/\text{m}^3$ ). Here, a stream of air is essentially saturated with R-112 vapor by passing it through a constant-temperature bubbler. This saturated stream is diluted twice with additional clean air to provide the needed low concentrations.

### 3.4 Operational Problems in Adsorber Testing

Most of the problems met in HEPA bank testing are met in adsorber bank tests. Adsorber cells (or bulk loaded units) are far less fragile than HEPA cells, hence less subject to damage. There are, however, additional problems inherent in adsorber bank (or module) tests: Dampers: Many systems have dampers by-passing adsorber banks, designed to eliminate ageing of the adsorber when they are not "needed", or to allow HEPA testing without polluting the adsorber bank. These by-passes could be leak-free, but the quality of dampers chosen have not been so. Ventilation system grade dampers allow leaks which by-pass 1 to 5% of the upstream gas directly into the downstream, thus making it impossible to hold bank leakage below 0.5%. Sometimes this problem has been overcome by ingenious expedients: taping plastic sheeting over the dampers, or welding them shut. The first expedient of course gives a very erroneous picture of system performance - through allowing an honestly effective filter bank to 'pass'. The second somewhat defeats the purpose of the dampers. Our recommendation is to eliminate dampers entirely; if this cannot be done, then massive cast-steel valves with O-ring seals must be used. Utility Interruptions: A power interruption is very troublesome with gas chromatographs and thermostatted boilers. Stabilization times are usually in the order of 12 hours; a two minute interruption can cause a delay of three or four hours while the system re-equilibrates. Some means of labeling the criticality of the circuits from which the test gear operates is needed - signs, locks, guards. This is particularly true during the construction and start-up phase of a plant, when there is tremendous competition for power outlets and priorities are determined by the brawn of the person in need of watts. Electrical Noise: Arc-welders and other electrical devices produce radiofrequency interference and line surges. These penetrate even well designed instrumentation, and while they do not necessarily abort tests, their effects should be watched for and marked on chromatograms, etc. Fluorocarbon Solvent Pollution: Background readings must be taken to assure that recent use of fluorocarbon solvents has not left concentrations which would indicate false leaks or overlap the test contaminant chromatogram peak.

### 4.0 GENERAL TEST PROCEDURES

Tests will proceed much more smoothly and reliably if they are pre-planned with proper calibration and test data sheets available. Equipment and operation checklists are needed, as are rigorous reporting forms which contain sufficient raw

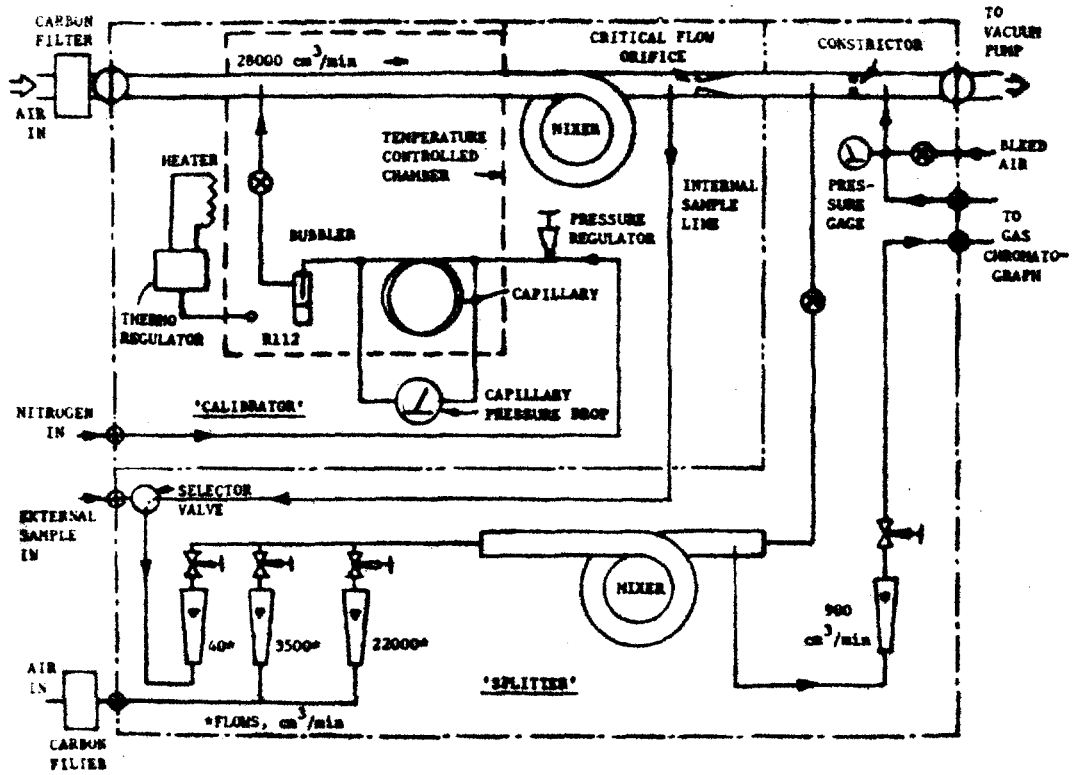

FIGURE 6. Calibrator/Splitter Schematic

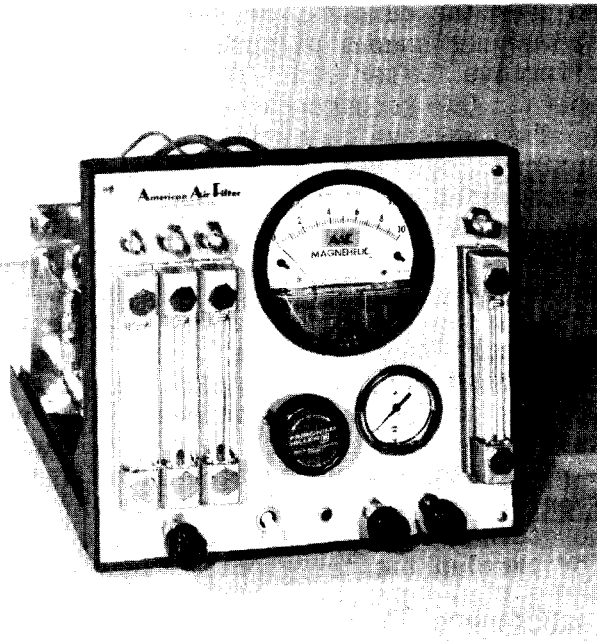

FIGURE 7. Calibrator/Splitter - Cover Removed

## 13th AEC AIR CLEANING CONFERENCE

data so that the customer can evaluate the quality of the tests. Parallel to these there must be equipment operating manuals and descriptions of test procedures, both for the benefit of the crew and those examining their work.

Test equipment must be packaged so as to arrive on-site, and move about the plant without damage. This means shipping cases of essentially military grade, with shock protection for the contents. Regular recalibration must be guaranteed. None of the above, of course, will assure meaningful testing if test crews are not properly instructed and committed to quality work.

### 5.0 SUGGESTIONS FOR IMPROVING SYSTEM TEST ABILITY

The following items could substantially improve the reliability and convenience of testing:

- Eliminate by-pass dampers.
- Provide adequate workspace and lighting at filter banks.
- Provide plenum space or ducting upstream of each bank for contaminant mixing.
- Provide properly located and sized penetrations to allow feeding tubing and power cords through housing walls during testing. An industry standard for a penetration fitting could be a useful thing, providing a leak-free interface to which the tester could bring his own, sealed penetration element.
- Provide control over utilities to avoid casual interruption of power and compressed air.
- Establish a dummy housing under the auspices of a university or other disinterested party, where test crews could be instructed, examined and certified, in the same way as 'code welders' and other technical specialists.

### REFERENCES

1. USAEC Regulatory Guide 1.52: Design, Testing and Maintenance Criteria for Atmosphere Cleanup System Air Filtration and Adsorption Units of Light Water Cooled Nuclear Power Plants (USAEC Directorate of Regulatory Standards, 1973)
2. American National Standard N101.1, Efficiency Testing of Air Cleaning Systems Containing Devices for the Removal of Particles (ANSI, 1972)
3. American National Standard N510, Testing of Nuclear Air Cleaning Systems (ANSI, tentative, 1974)
4. American National Standard N509, Nuclear Power Plant Air Cleaning Units and Components (ANSI, tentative, 1974)
5. Burchsted, C.A., and Fuller, A.B.: Design, Construction and Testing of High-Efficiency Air Filtration Systems for Nuclear Applications (ORNL-NSIC-65) ORNL, 1970
6. Zavodski, R.W., Gilbert, H., Fuller, A.B., and Burchsted, C.A.: Engineer Safety Features for Air Cleaning Systems for Commercial Light-Water-Cooled Nuclear Power Plants (WASH-1234, VC-80) USAEC-DRL, 1974
7. Penetrometer, Filter Testing, DOP, Q107 (DLD-76-2-639) Edgewood Arsenal Division of Quality Assurance, Edgewood, Md.
8. Rolie, A.G., Adley, F.: High Capacity DOP Aerosol Generator in Proc. 12th AEC Air Cleaning Conf. (USAEC-CONF-720823)(NTIS, Springfield, Va. 22152) 1972
9. USAEC Health and Safety Bulletin 306: Revised Minimal Specification for the High Efficiency Particulate Air Filter (USAEC Div. Operational Safety, 1971)



## 13th AEC AIR CLEANING CONFERENCE

### DISCUSSION

METCALFE: I am designing many of the filter systems to comply with AEC Regulatory Guide 1.52. If they comply with 1.52, can they be tested in accordance with the inspector's criteria?

O'NAN: Systems in compliance with Regulatory 1.52 are available now and others on the drawing board will be available shortly. The Regulatory Guides have been followed to date and they will ease many of our problems. Some systems may, sometimes, have to be tested by a modular method. We have tested one at the present time; we had no real problems with that particular one.

GIMAIL: You mentioned the bypass problem. Using two bypass dampers in series and pressurizing the space between them by air taken from the fan discharge would eliminate contaminated air bypassing the filter.

O'NAN: That could be accomplished in a good system with cast steel fittings and o-rings seals. It would probably work. Most of the systems have a leakage rate of approximately one percent. It is very difficult to do better.

HALLIGAN: The Freon calibrator diluter system is very original. How does it compare in accuracy with the calibration method? Even though it is very repeatable, how sure are you of its accuracy?

O'NAN: The calibrator diluter we are describing in our paper is an original design. For me to answer this question will require much time. I am not dodging that question, if we have the time.

HALLIGAN: Could you make a general comment on the use of dilution air systems versus a dual loop with two different sized loops in it?

O'NAN: The dual loop will work fine with dilution air. You have a little bit more control of it and your repeatability is, therefore, going to rise.

# 13th AEC AIR CLEANING CONFERENCE

## THE AEC REGULATORY VIEW OF THE RELIABILITY OF AIR CLEANING SYSTEMS IN NUCLEAR FACILITIES

R. R. Bellamy and R. W. Zavadoski  
USAEC  
Directorate of Licensing  
Bethesda, Maryland

### Abstract

Air cleaning systems in nuclear facilities can be divided into three categories: ventilation exhaust systems, containment atmosphere cleanup systems, and process offgas systems. These systems have been the subject of numerous reports, regulatory guides, discussions, and meetings. Some of the analyses have been critical of the operation and design of these air cleaning systems -- in particular, the engineered safety features containment atmosphere cleanup systems. Although for the most part the criticism is applicable, and recognizing that there are a number of unresolved issues pertaining to gaseous waste management systems, there are data to show that air cleaning systems in use in nuclear facilities are performing their intended function.

### I. Introduction

Appendix A to 10 CFR Part 50 lists General Design Criteria for Nuclear Power Plants. Criteria 41, 60 and 61 are concerned with, in part, the control of releases of gaseous radioactive materials in gaseous effluent to the environment surrounding nuclear facilities. These Criteria deal with containment atmosphere cleanup following postulated accidents, releases of gaseous effluent from the nuclear power plant during normal operation including anticipated operational occurrences, and releases from associated reactor equipment (such as fuel storage and handling systems) under normal and postulated accident conditions. The Regulatory staff of the AEC is responsible for implementing the Commission's regulations in Appendix A to 10 CFR Part 50. Today these regulations are generally met by air cleaning systems using air filtration or adsorption units, or both.

The components of the air cleaning systems installed in exhaust ventilation systems may include provisions for moisture removal, high efficiency particulate (HEPA) filters, radioiodine adsorbers, and the necessary ducts and valves, fans, and instrumentation. Containment atmosphere cleanup systems generally include the same components, and also prefilters before the initial HEPA filter <sup>(1)</sup>. Process offgases from light-water-cooled nuclear reactors are generally treated by holdup in gas decay tanks (pressurized water reactors), holdup in charcoal adsorber systems (boiling water reactors), or cryogenic distillation columns. These systems have been the subject of numerous critical analyses recently, which at first glance seem to discredit the reliability of these air cleaning systems. Are these systems as unreliable as one might be led to believe? Or are they serving their intended purpose?

## 13th AEC AIR CLEANING CONFERENCE

The abnormal occurrences concerned with air cleaning systems are real, as Dr. Moeller<sup>(2)</sup> has outlined, and there are a number of unresolved issues, but in general, one should be quite satisfied with the performance of air cleaning systems in nuclear facilities.

### II. Discussion

Dr. Moeller<sup>(2)</sup> has presented a summary of the failures of air cleaning and gaseous waste management systems in use in nuclear facilities since 1966. The failures have included disruption of process offgas systems due to hydrogen explosions in delay lines, contamination of HEPAs, the failure of seals and damper controls, and inadequate sampling techniques coupled with procedural errors resulting in improper evaluation of the systems. Most of the incidents reported occurred in BWR offgas systems -- explosions in the delay lines. These explosions have occurred due to ignition of the hydrogen (in stoichiometric quantities with oxygen) that is normally present in the offgas system. The explosion results when an ignition source is present (welding torches, electrical shorts, lightning storms). Acceptable solutions to this problem include better grounding of the filters, increased purging to reduce concentrations of contaminated gases, or the use of a conducting glue as part of the filter seal.

In a paper prepared by Mr. Burchsted, the design and construction of engineered safety features of air cleaning systems are reviewed. Reported in WASH-1234<sup>(3)</sup>, the subject matter reflects the observations and conclusions of the authors drawn from field trips and discussions with operating personnel. The photographs presented of ESF air cleaning systems illustrate the structural considerations, maintainability, testability and reliability. The critique of these ESF systems is in terms of Regulatory Guide 1.52, "Design, Testing and Maintenance Criteria For Atmosphere Cleanup System Air Filtration and Adsorption Units of Light-Water-Cooled Nuclear Power Plants", and the discussion uses terms such as "inadequate", "insufficient", "shortcoming", "poor access", "absence of access", "obstructions", and the like. It is important to recognize that the systems under review were designed and constructed prior to the issuance of Regulatory Guide 1.52, when more conservative assumptions were used by the Regulatory Staff regarding air cleaning efficiencies. The failure of these systems to meet the recommendations and guidance of the Regulatory Guide should not be construed as requiring corrective action to assure the public health and safety.

The Regulatory Staff does not require that activated charcoal be used as the adsorbent for radioiodine in air cleaning systems, but most available adsorption data are concerned with charcoal, and this is the adsorbent most commonly used. Two immediately recognizable problems of charcoal adsorbents are charcoal heating leading to possible ignition, and the aging and poisoning of the charcoal due to the presence of contaminants over extended periods of operation.

In a paper prepared by Dr. Emile Bernard of the Regulatory Staff, the staff's calculational technique for charcoal heating in air filtration systems will be presented. Two sources of heat are considered -- decay heat and charcoal oxidation. Dr. Bernard will show that under certain circumstances decay heat alone is not of sufficient magnitude to lead to charcoal ignition, but the addition of oxidation effects may provide enough heat to ignite the

## 13th AEC AIR CLEANING CONFERENCE

charcoal. Coupled with experimental verification of the suitability of spray protection systems to extinguish charcoal fires within minutes<sup>(4)</sup>, it is concluded that charcoal ignition is not a major concern.

The effect of aging on charcoal has been demonstrated in a number of instances. These include the work of Taylor and Taylor<sup>(5)</sup> of the UKAEA on real-time dynamic aging of an installed full-scale iodine trapping plant, and similar work performed by Dr. Wilhelm at the Karlsruhe Nuclear Research Center and reported at the 12th AEC Air Cleaning Conference<sup>(6)</sup>. The offgassing of paints and other organic materials, more prevalent in reactor environments during the first year of operation, may lead to accelerated aging of charcoal during this time period. More frequent testing of air cleaning systems should be made during this startup period to observe aging effects and permit meaningful predictions of performance.

The testing of iodine adsorbers is another problem area. Guidance in obtaining a representative sample is contained in Regulatory Guide 1.52, where it is recommended that there be a "sufficient number of representative samples located in parallel with the adsorber section for estimating the amount of penetration of the system adsorbent throughout its service life". This implies that sample cartridges be designed and installed so that the bed depth of the sampler is the same as the bed depth of the adsorber cells and so that the air flow velocity through and residence time (of contaminant gases) in the sampler are the same as those of the adsorber cells. If this guidance is not followed, and the surveillance samples are not representative of the adsorbent in the banks, the samplers serve little or no useful purpose. In practice, obtaining a representative sample is no easy task. One acceptable method requires unloading an actual adsorber bed and removal of a representative sample of the adsorbent for testing, although the potential for radiation exposure is increased.

In conjunction with the subject of aging of charcoal adsorbers, a major problem of air cleaning systems used in building exhaust ventilation systems is the inability to predict the performance characteristics of charcoal at low radioiodine inlet concentrations ( $10^{-11}$  to  $10^{-13}$   $\mu\text{Ci/ml}$ ) over extended periods of operation. A recent evaluation of the data available was conducted by Ritzman and Genco<sup>(7)</sup>, and they concluded that the several rather isolated reports of experimental studies available in the literature tend to indicate the retention efficiency for gaseous iodine might decrease with concentration at very low gas phase iodine concentrations. The individual reports and the conclusions are still subject to discussion, and the problem has not yet been resolved. There are a number of experimental studies being conducted by both filter manufacturers and independent testing firms in an effort to obtain performance data at these low inlet concentrations, but results are not available to date.

A significant problem of BWR offgas systems is an accident or upset condition of the delay pipe or charcoal adsorber system. However, as Mr. Dyer will discuss<sup>(8)</sup>, the calculated off-site doses resulting from such an abnormal occurrence are below the limits of 10 CFR Part 100 at the boundary of the exclusion area. Additional concern for the possible doses resulting from ineffective air cleaning systems, whether they are the result of operation during normal or accident conditions, is found in Regulatory Guide 8.8<sup>(9)</sup>, entitled "Information Relevant to Maintaining Occupational Radiation Exposure As Low As Practicable". It is the intent of this guide to provide guidance to ensure that radiation exposures to operating personnel are as low as practicable.

## 13th AEC AIR CLEANING CONFERENCE

How should effective control of radiation exposure from air cleaning systems best be accomplished? Regulatory Guide 8.8 indicates a number of considerations, the most important being careful design and installation of the facilities and equipment. Other considerations include management commitment and support to reduce radiation exposures to operating personnel, coupled with the enforcement of good radiation protection practices.

There have been recent developments of new design techniques for air cleaning systems, including shop fabricated housings, gasketless adsorbers (all welded construction) and tray-type adsorbers for ease of change-out. These practices should aid in keeping doses as low as practicable, but they are not enough. In-containment ESF systems for containment atmosphere cleanup is regarded as a step in the right direction.

Other issues pertaining to air cleaning systems include considerations of the new breed of reactors being proposed. What air cleaning systems should be provided for the Gas Cooled Fast Reactor? What are the major release points of gaseous radioactivity for these facilities?

The same questions must be resolved for the Liquid Metal Fast Breeder Reactors. It is hoped that the Fast Flux Test Facility, now under construction, will provide meaningful operating data on the use of an argon cover gas, and the removal of radioactive kryptons and xenons from this cover gas, in an LMFB. But in lieu of suitable operating data, it will be necessary to use our best engineering judgement, based on the best information available at the present time.

This discussion of abnormal occurrences and the many unresolved issues pertaining to air cleaning systems should not diminish our faith in the reliability of air cleaning systems. No accidents of major importance in these systems have been reported. You will also be exposed today to field experience and operational characteristics of the Vermont Yankee Advanced Offgas System<sup>(10)</sup>. Nine months of operation has demonstrated the system to be performing better than design requirements. The San Onofre cryogenic offgas system<sup>(11)</sup> demonstrates a similar tendency. Operational data are also available for four of the German reactors<sup>(12)</sup> - KWL Lingon, KRB Gundremmingen, VAK Kahl, and KWO Obrigheim. The releases of noble gases and iodines through the offgas systems, and of particulates and iodines through the ventilation exhaust systems are all generally a small fraction of the plant Technical Specifications.

Some experts believe that the cost of a process offgas system is prohibitive. Let us use  $\$10^7$  as a reasonable figure today for an installed air cleaning system on a 2000 MWt reactor<sup>(13)</sup>, that will gross approximately  $\$10^6$  per day<sup>(14)</sup>. Let us assume that this system, designed to treat the condenser off-gases of a BWR, is properly operated and allows operation without requiring a 10% reduction in power, thereby resulting in a savings of 10% of  $\$10^6$  per day, or  $\$10^5$  per day. On this basis the offgas system would pay for itself in 100 days of plant operation, or less if the plant was forced to shut down because of no offgas system. On a pay out time of 100 days, one can justify the installation of a process offgas system based on its cost. Such a scenario is reasonable, considering the operational experience of Quad-Cities Units 1 and 2, Monticello and Dresden 1. The Quad-Cities units were forced to reduce power from 100% to 90% from April 16-19, 1973<sup>(15)</sup> due to offgas rates in excess of the Technical Specifications and from July to December 1973<sup>(16)</sup>, power was reduced ten times due to offgas rates in excess of the plant Technical Specifications. These reductions generally were of a one day duration, and the power

## 13th AEC AIR CLEANING CONFERENCE

reductions were from 10% to 75%. A power reduction of approximately 10% at Monticello<sup>(17)</sup> lasted from November 8 to November 13, 1973, at Dresden-1 a 15% to 25% reduction in power occurred for the last half of 1972<sup>(18)</sup> and a 50% to 75% reduction in power in the first half of 1973<sup>(19)</sup>.

### III. Conclusion

In conclusion, one cannot deny the abnormal occurrence record of the air cleaning systems, the existence of unresolved specific issues, and the probable development of new and unique problem areas. But the lack of a history of large-scale failures of air cleaning systems, the fact that there is recognition of unresolved issues and steps are being taken toward their solutions, and the examples given of exceptional operating characteristics, should leave us with a high level of confidence in the reliability of the air cleaning systems employed today in nuclear facilities.

### References

1. USAEC Regulatory Guide 1.52, "Design, Testing, And Maintenance Criteria For Atmosphere Cleanup System Air Filtration And Adsorption Units Of Light-Water-Cooled Nuclear Power Plants", June 1973.
2. D. W. Moeller, "Performance of Air Cleaning Systems in Nuclear Facilities", Paper Presented At The Thirteenth AEC Air Cleaning Conference, San Francisco, California, Aug. 12-15, 1974 (to be published).
3. R. W. Zavadoski, et al, "Engineered Safety Features Air Cleaning Systems For Commercial Light-Water-Cooled Nuclear Power Plants", USAEC Report WASH-1234, USAEC Directorate of Licensing, Washington, D.C., June 1974.
4. "Progress Report On Water Spray Test Being Conducted By The Grinnell Fire Protection Systems Company, Inc., On Equipment Supplied By CVI Corporation", submitted by CVI Corporation, Columbus, Ohio, April 1974.
5. L. R. Taylor, and R. Taylor, "The Aging of Impregnated Charcoals", Paper Presented At The Seminar On Iodine Filter Testing, Karlsruhe (West Germany), 4-6 December 1973.
6. J. G. Wilhelm, H. G. Dillman, and K. Gerlach, "Testing of Iodine Filter Systems Under Normal And Post-Accident Conditions", in Proceedings of the Twelfth AEC Air Cleaning Conference, Oak Ridge, Tennessee, Aug. 28-31, 1972, USAEC Report Conf-720823, Vol. 1, pp. 434-444, 1972.
7. R. L. Ritzman and J. M. Genco, "Evaluation Of Data Regarding The Efficiency of Activated Charcoal Adsorbers At Low Gas Phase Iodine Concentration", Battelle Columbus Laboratories, Columbus, Ohio, May 31, 1972.
8. N. C. Dyer, et al, "BWR Waste Gas Treatment System Dose Evaluations Under Upset Conditions", Aerojet Nuclear Company, National Reactor Testing Station, Idaho Falls, Idaho, May 1974.
9. USAEC Regulatory Guide 8.8, "Information Relevant To Maintaining Occupational Radiation Exposure As Low As Practicable (Nuclear Reactors)", July 1973.

### 13th AEC AIR CLEANING CONFERENCE

10. P. S. Littlefield and S. R. Miller, "Vermont Yankee Advanced Offgas System", Paper Presented At The Thirteenth AEC Air Cleaning Conference, San Francisco, California, Aug. 12-15, 1974 (to be published).
11. G. M. Thrall and D. F. Pilmer, "A Cryogenic System For Processing Waste Gas From A PWR Generating Station", Paper Presented At The 19th Annual Meeting Of The Institute Of Environmental Sciences 'Realism In Environmental Testing And Control'", Anaheim, California, April 2-5, 1973.
12. R. Bodege, et al, "Activity Release And Control At The Nuclear Power Stations KWL Lingen, KRB Gundremmingen, VAK Kahl and KWO Obrigheim", Paper Presented At The Fourth United Nations International Conference On The Peaceful Uses Of Atomic Energy, Geneva, Switzerland, Sept. 6-16, 1971 (A/Conf. 49/P/396).
13. Private Communication with P. S. Littlefield, Yankee Atomic Power Company, June 27, 1974.
14. Statistical Yearbook Of The Electrical Utility Industry For 1972, Edison Electric Institute, New York, p. 54, Table 47-5, 1973.
15. Quad Cities Nuclear Power Station, Commonwealth Edison Company and Iowa-Illinois Gas & Electric Company, "Units 1 & 2 Semi-Annual Report January 1, 1973-June 30, 1973".
16. Quad Cities Nuclear Power Station, Commonwealth Edison Company and Iowa-Illinois Gas & Electric Company, "Units 1 & 2 Semi-Annual Report July 1, 1973-December 31, 1973".
17. Northern States Power Company, Monticello Nuclear Generating Plant, "Six Month Operating Report No. 6 July 1, 1973 to December 31, 1973".
18. Dresden Nuclear Power Station, Commonwealth Edison Company, "Dresden Units 1, 2 and 3 Semi-Annual Report July 1, 1972-December 31, 1972".
19. Dresden Nuclear Power Station, Commonwealth Edison Company, "Dresden Units 1, 2 and 3 Semi-Annual Report January 1, 1973-June 30, 1973".

## 13th AEC AIR CLEANING CONFERENCE

### DISCUSSION

MORRIS: One is tempted to ask what ten million dollars would do for fuel oil quality assurance. Are there questions from the floor?

STEVENS: What is generally accepted as a lifetime expectancy for charcoal?

BELLAMY: To answer that, I think you would have to say whether you are talking about a normal ventilation system, an ESF system, or an offgas system; and the type of reactor.

STEVENS: 400 megawatt PWR systems.

BELLAMY: Are you talking about normal ventilation, and where is the charcoal in the reactor?

STEVENS: Normal.

BELLAMY: The answer to that would be, "We don't know."

MORRIS: A man of integrity!

BURCHSTED: You conclude that fire in charcoal is not a major consideration. Can you comment on heating to the point that desorption occurs?

BELLAMY: I think that sufficient heating to cause desorption of iodine or impregnant should certainly be considered.

WILHELM: I get a little nervous hearing such an answer. As far as our experience goes, the less time you can take for testing, the longer continuous operation you will experience. The amount of money spent for testing may, over the long run, be higher than the amount of money needed for bed renewal.

SULLIVAN: One of the requirements of Regulatory Guide 1.52 is that non-ESF systems be designed to retain collected radioactivity in the event of a DBA. Isn't it true that any collected radioactivity would be negligible compared to the activity released in a DBA of sufficient magnitude to destroy a filter or adsorber system?

BELLAMY: My personal opinion is, yes. However, I am not an authority on Regulatory Guide 1.52 and the author is not with us. To find out what he meant, you would have to talk to him.

MOELLER: Did the speaker say that in the case of an explosion in an offgas system in a BWR, the dose limits specified by 10 CFR 100 were not to be exceeded at the site boundary or low population zone? I wonder if your implication was that this was a type of accident that 10 CFR 100 would routinely be applied to?



### 13th AEC AIR CLEANING CONFERENCE

BELLAMY: Yes, that is what I said. I think Dr. Dyer can say a lot more on that when he presents his paper. I would have to say, I hope such accidents don't happen.

ALTMAN: You talked about a representative sample. Please define a representative sample?

BELLAMY: I assume we are talking about charcoal. I define a representative sample of charcoal as a quantity of charcoal that, when tested, will tell me exactly how all charcoal in the filter performed during the operation of the system.

ALTMAN: Are you interested in determining where the charcoal was while air passed through it?

BELLAMY: I think you are asking me, "Am I interested in where the sample of charcoal that I am going to test came from in relation to the whole air flow?"

ALTMAN: Are you interested in knowing the granule position when you test the sample? In other words, the charcoal sent to the laboratory may have been shaken up. Are you interested in the position, in the event it was shaken?

BELLAMY: From the point of view of how well the charcoal operates, I am not. From a scientific point of view, I am.

BURCHSTED: I think the answer to his question is that we want to know where the sample is located in the bank because we are concerned that the sample has seen essentially the same air flow as the total bed. Therefore, it is important where you locate a sampler in the system. It must be subjected to the same flow and "poisoning" conditions as the bed.

BELLAMY: Yes, that's true. Referring to a two-inch bed of charcoal: if we take a sample of that charcoal and it gets shaken up before we test it, we will be unable to determine if the charcoal that tests all right is at the entrance to the bed or at a depth of an inch or more. We are worried about that. I would certainly want to make sure that the sample of charcoal tested was not off in a corner where there was no air flow.

GARY: You must be concerned with where, within the bed, the sample comes from as most of the aging occurs at the front face. If you are sampling from the back face, you are going to get erroneous results with regard to the performance of the carbon.

BELLAMY: I agree with that but I also would like to see the charcoal kept in the exact same configuration during testing as during the operation. I don't want to see charcoal shaken up before testing.

### 13th AEC AIR CLEANING CONFERENCE

FICKS: With respect to knowing where samples are located in a filter bank, in ANSI-N-510 we have a test (not approved yet) that involves uniform distribution of air. I don't think it's too critical, if the bank passes this test, where you pick them. I would not recommend locating the samples at the perimeter of the cells. The samples should see the same ambient conditions of contaminants and flow as the installed adsorber.

BELLAMY: Yes, I hope that's right. What we would like to get away from is a filter system at one level and charcoal samples at a level higher so that you can't say the air flow through the samples is the same as the air flow through the charcoal bed.

HYDU: Would you consider 70 percent as representative?

BELLAMY: I would consider that representative.

SHAPIRO: I would like to clarify a statement you made concerning the results of the paper prepared by Cliff Burchsted on ESF air cleanup systems. The failure of these systems to meet the recommendations and guidance of the Regulatory Guide should not be construed as requiring corrective action to assure the public health and safety. My understanding of the purpose of the guides is to assure the health and safety of the public. Systems that do not meet these recommendations would require corrective action for this purpose.

BELLAMY: What I am trying to say is that parts of the guide have to do with testability and maintainability. If we go back and start changing a lot of these systems, we will run into a major backfit problem.

SHAPIRO: Should information of this sort be put in a regulatory guide?

BELLAMY: I think so, yes.

SHAPIRO: You don't feel that it's the domain of the architect engineers or the utilities to develop these parameters if they do not affect the health and safety of the public.

BELLAMY: I think we should consider the regulatory guide as a step toward the standardization of plans and, since I am employed by the Commission, I am 100 percent for standardization.

SHAPIRO: I would go on record in favor of standardization, also.

# 13th AEC AIR CLEANING CONFERENCE

## THE USERS VIEW OF THE RELIABILITY OF AIR CLEANING SYSTEMS IN NUCLEAR FACILITIES

J. Louis Kovach  
Nuclear Consulting Services Inc.  
Columbus, Ohio

### Abstract

The state of the art of air cleaning systems has advanced, but a wealth of knowledge did not result in a commensurate increase in the improvement of the design, manufacture, and operation of air cleaning systems. Often the developed data is not available or known to the designer, equipment supplier or operator.

There are still systems installed where the equipment will operate under the specified criteria only when it is new and little thought is given to the subsequent maintenance and operating problems. The dissemination of available information to all of those concerned with the design, construction, installation, and operation of air cleaning systems through relevant standards, guides, etc. is unsatisfactory at the present time.

### I Introduction

Basically there are only three reliability problems with air cleaning systems: design, construction, and maintainability. There were some obvious improvements in all three of these areas but none of them are at the level where it should be, based on prior manhours and dollars expended.

### II Design

Design problems are still compounded by the insufficient space allocated for the air cleaning systems by architect engineers. On the surface it appears that the HVAC designers are the last ones in line for space allocation. Although space problems were repeatedly discussed in the past, even today there are specifications out for bids where ceiling support columns penetrate through the air system housing.

The air distribution, partly as a result of space saving and partly through lack of attention paid to the subject, is very uneven in most existing air cleaning systems. Entrance velocities to a filter bank often vary by as much as  $\pm 50\%$  of the so called designed value.

Current standards and guides often aim at solving problems which are already solved, while not addressing still existing ones. As an example ANSI standards in preparation discuss or reference in great detail specifications for shallow bed (1 and 2 inch deep) adsorbents, while very little is said about the deep bed systems even though some of them are in operation for up to a year and the current trend is certainly in the direction of deep beds.

Another typical design deficiency is in the use of water sprays on the adsorbent beds. Not only is there no data indicating that the water spray would in fact put a fire out, the experimental data indicates that iodine would desorb long before ignition can take place. Even today, although deep beds are used, ignition evaluation is standardized on one and two inch carbon beds

## 13th AEC AIR CLEANING CONFERENCE

while experimental data indicates that in deep beds due to oxidation, prior to ignition, when operated at low air velocity and high humidity, ignition may take place at as low as 80°C. Additionally, experimental data indicates that the action of water spray on carbon beds initially increases the carbon temperature, due to heat of water adsorption, and in fact assists in the release of the iodine from the surface. (2)

To summarize the experience of fire hazards in power reactor air cleaning systems, to date one was destroyed by fire where water spray was not used to extinguish the fire and three were destroyed by accidental initiation of the water spray, when there was no fire. On this basis, the major problem is the water damage. This is a typical example where a safeguard causes the lack of reliability. Several new systems proposed CO<sub>2</sub> cooling - fire extinguishing systems; whether the new systems were tried and found to keep temperatures low or to prevent fire is not known.

Very often adsorbent beds are designed on the basis of extrapolated data without understanding either basic adsorption or decontamination data. As an example, on the basis of a single deep bed CH<sub>3</sub>I efficiency reference of 10<sup>11</sup> - 10<sup>14</sup> DF, this number was applied to a standard 2 inch deep adsorber operating at rated velocity. While in fact, for such continuously operated 2 inch deep system, one can hope for the best at 10 DF for methyl iodide.

There are significant design problems with adsorbent poisoning rates, modes, and subsequent effects also. As an example a new impregnated carbon which demonstrates a DF of 10<sup>2</sup> for a two inch deep segment showed less than a 5 DF when placed downstream to a used (poisoned) segment. This shows that particularly an integral, initial poisoned segment can decrease the efficiency of subsequent unpoisoned segments, if the adsorbed impurity migrates faster under the iodine exposure than under normal operating conditions (i.e. higher humidity, temperature, etc.).

Again the phenomena of poisoning, weathering, aging, etc. is known for over six years and still many utilities are caught short with insufficient efficiency in the installed adsorbers and no spares on hand.

Many of the currently installed sampling cartridges are not representing the actual residual efficiency of the adsorber cells. In several instances where adsorbent media was removed from both the cartridge and one of the cells in the bank, the cartridge showed near double the efficiency of the actual cell. Often installation or cell filling time, base iodine decontamination, efficiencies are lacking on the adsorbent batch, therefore the starting time for aging and/or weathering can not be established.

Although a great wealth of design information and sizing data exists, only fragments of these are known to designers and evaluators, (based on the questions originating from the regulatory agencies), indicating the desirability of some central location where the data should be stored and disseminated to all of those who design systems to permit increased reliability of design. Additionally it is important that standards and guides are prepared or reviewed by both of those who are familiar with the design problems and those who operate the systems.

## 13th AEC AIR CLEANING CONFERENCE

In general, the available theory is still not being translated into design, which means that not only systems in existence have design deficiencies, but those currently specified are not necessarily based on all of the available design information.

### III Construction

The major manufacturing deficiencies are often caused by the non-integration of the equipment supply responsibility. As an example many so called high efficiency systems are connected to leaky duct works (for which by the way there is a scarcity of standards) and unsealed blower housings.

The use of only a single properly designed segment in an air cleaning system does not result in a high efficiency integrated system. There are still problems with components also. Typically perforated plate in cells or adsorbers is turned with the rough side toward the carbon. Due to vibration and the air velocity this tends to generate dust. The "smoothness to the touch" is really irrelevant from a technical design standpoint.

Many installed or currently designed systems call for redundant units with heaters to assure a maximum of 70% relative humidity. However, during operation, the standby unit heater is not operating and condensation of water can take place in the standby side. In one such case the resulting corrosion was so great that not only the screen but the adsorber sides corroded through, under the action of the impregnant iodides. It has to be remembered that iodides are almost as corrosive as chlorides and condensation in the adsorbent beds should be avoided at all costs.

There are also frills which somehow keep evading the knowledge that they are unnecessary. Such an example is the use of glove ports in air cleaning system housings. No one knows what to use them for or why they were installed and still systems are supplied with such amenities. Some strange practices also crop up; several adsorber banks were installed where the adsorber gaskets were heavily coated with grease. The quantity of grease was such that both the holding framework and adsorber metal parts were also heavily contaminated; whether this represents lack of faith in the gaskets or "fixing" of initial leak paths is not known, but certainly no standards or guides cover such practice.

Several adsorbent banks were found to have low initial installed adsorbent efficiency. The only known contamination exposure prior to on-site installation could have taken place at the equipment suppliers location. This indicates that the practice of loading or "testing" of adsorbers in welding fume, degreaser and paint solvent filled assembly shops still exists. Those responsible for the mechanical manufacturing of systems have to be made aware that most of the adsorbents are non-selective and can be poisoned by any organic compound, not only the ones found in reactor environments.

Many adsorbent beds are still supplied with the original "shop test" halide adsorbed on the carbon; such systems, particularly on new reactors, require on-site blow out of the shop test halide, which in turn results in the adsorption of various organic contaminants such as paint fumes, which are present in the atmosphere of a power reactor in its final stages of construction. Thus the adsorbent bed is highly contaminated at the beginning of its life.

## 13th AEC AIR CLEANING CONFERENCE

### IV Maintainability

Because air cleaning systems for anticipated reactor start-up dates of 1980-1982 are designed now while detailed construction and testing ANSI standards are still in the approval stage, a significant quality lapse will occur for many air cleaning systems. The non-familiarity of designers, specifiers, and owners with this in development criteria will result in a 6-8 year delay in the conformance to by then approved standards.

Most air cleaning systems are still built on the assumption that they will always operate at the maximum rated efficiency. The design incorporates test capability for proofing high efficiency but creates difficulties in locating and repairing leaks, weld failures, etc. if the designed for efficiency is not found after a test. Such an example is typical access space of 4-6 inches between built in adsorber plates. If such a system develops a leak, which shows up in the integrated test, the precise location of the leak is very time consuming if not impossible and the repair cost can be very high.

Approximate calculations indicate that replacing vertical banks of contaminated tray type adsorbers can result in radiation dose of 100 mr/hour/C of <sup>131</sup>I. All one has to do is look at the location, entrance and working space limitation of adsorber systems to realize the problems associated with replacement of contaminated adsorbers even after a relatively minor release. At the same time many of the details of remote unloading contaminated adsorbents from built in adsorbers is not resolved. Take the case of a large Kr-Xe delay bed where it is postulated to remove carbon by opening the blind flange at the bottom of the adsorber. Many tons of contaminated carbon will be pouring out immediately and the resulting clean-up costs and potential personnel exposure can be anybody's guess.

Another maintainance problem exists with the testing and/or servicing of in-containment air cleaning systems. Often very high neutron dose exposures result from the physical location of such systems. It is imperative that such systems be equiped with remote monitoring and test devices.

The difficulty of calibration of chromatograph type halide leak detectors also can result in tests which would not show leaks smaller than 0.1% through an adsorber bank. Often the test equipment supplied with the air cleaning system is designed for laboratory rather than field testing.

There are also deterioration effects for which no known tests exist. Such an example is the aging of HEPA filters. While they may show a high DOP removal efficiency the glass media, due to aging, can become very fragile and may not stand up to vibration, slight mechanical shock, or accident conditions. Criteria for HEPA filter media aging and deterioration needs to be established.

### V Standards, Guides, Regulations

Many of the criteria documentation does not encourage better design and in fact can encourage "good enough" and "why do better" attitude. The establishment of credit system is still haphazard and non-uniform. Often regulatory questions are based on problems which were resolved a long time ago. The existence of insufficient information in the hands of regulatory agencies regarding the design data, even if available in the open literature, is often demonstrated.

## 13th AEC AIR CLEANING CONFERENCE

There is still a polarization based on regulatory using the worst results and designers the best results without evaluating the circumstances under which the particular data was developed. In most cases the operational data appears to be in the middle of the quoted numbers.

However, at times, arbitrary designation of numbers can result in non-conservatism. Such an example is the credit of low Kr dynamic K numbers for noble gas delay will show significantly lower inventories of radioactive noble gases in the first adsorber beds. Or the overemphasis on gaseous iodine species, however exotic they may be, while virtually ignoring many of the particulate forms.

Another misleading criteria is the current RDT standard for iodine adsorbent evaluation as it relates to high temperature, high pressure, steam-air tests. In case of a contaminated adsorbent, "preequilibration" treatment removes all of the impurities which adversely affect the iodine removal capability of the particular adsorbent by basically "regenerating the adsorbent prior to the admission of the radioactive iodine." At the same time there is no assurance that the sequence of events will follow the RDT standard.

### VI Summary

The reliability of air cleaning systems improved but the improvement is uneven in different fields and not necessarily keeping current with the availability of design and other test information. The current long lead time and licensing process in fact slows the installation of improved more reliable systems by creating a 5-8 year lag between the availability of new data and the standards to which systems are built. The dissemination of design, construction, and operating experience data is unsatisfactory.

### References

1. Bratzler, K. "The self-ignition of carbon adsorbents as a process problem." Chemie Eng. Tech. 28, 8/9, 569-576 (1956)
2. Marble, R. The Farr Company, Personal Communication. (1972)

## 13th AEC AIR CLEANING CONFERENCE

### DISCUSSION

B.A. SMITH: I would be interested in hearing some more details about the comments you made on deterioration of filter elements during their operating life. You didn't know, as I recall, whether radiation or moisture effects were responsible for it?

KOVACH: That is correct. We have observed this for several years and found that the structural strength of glass media deteriorated significantly when compared to new media.

B.A. SMITH: They would be much more likely to give way under moderate pressure, then?

KOVACH: That is correct. Some media, or filter, manufacturers may have additional comments. I would be happy to show you the location where this occurred.

PARISH: A couple of points in the paper were made concerning contaminants or poisons of the carbon. In the first of which, you indicated that poisoned carbon upstream resulted in a decrease of efficiency in carbon downstream. In other words, the contaminant progressed into the good carbon and accelerated its aging. The other comment was relative to the RDT test in which you suggested the carbon could be stripped of the contaminant during the test. These comments would appear to be addressed to a volatile contaminant which I would not think would represent the common aging due to nitrogen oxides and so on. I was wondering what contaminants are referred to here. These apparently are relatively volatile contaminants.

KOVACH: I cannot identify the contaminants. The particular adsorbents were removed from an operating power reactor. They represent actual conditions. Normally, for a standard efficiency test, you have to use guard beds downstream of the test unit. You find these guard beds significantly less efficient when used downstream compared with their efficiency when used by themselves: even at an equivalent concentration.

GOULET: On this question of deterioration of filters, are you referring to a paper given by Jim Little at the last meeting or is this other specific evidence?

KOVACH: I'm not referring to that paper. We found that only a little vibration or shock tends to deteriorate aged media. This is the case of the plant in standby. You could see some of the media deteriorating. It had been installed two and a half or three years ago.



## 13th AEC AIR CLEANING CONFERENCE

### CLOSING REMARKS OF SESSION CHAIRMAN:

MORRIS: I would like to thank each of the speakers for their interesting talks. We certainly covered a wide spectrum of views on the subject. I think one is impressed that we have been in the nuclear business for some 25 years and air cleaning systems are still in the developmental stage. I don't think we should lose sight of the fact that the philosophy of nuclear control has matured tremendously during the last four or five years and changed our concept of how to design air cleaning systems.

I would, along these lines, say we suffer in these areas as we do in others because of a lack of communication. That's one of the things we can do something about in the Commission.

I would like to make the same plea that some of you have talked about; namely, that you report the system as out for two hours or ten days and that you report the root cause of why that system failed so the designers know what has to be done to fix it.

I find a lot of the information on abnormal occurrences is not in the nuclear end of the business but is occurring as a result of failures in other parts of the system. I urge you to look for the root cause of failure and when we find it, I think then it behooves us to communicate the information to each other.

I would like to comment on a conflict between standardization as a philosophy and as practiced. I think we ought to be attempting to formulate a philosophy analogous to that used for radiation control. Critics ask if we are doing all we can from an engineering point of view to achieve reliability. Are we taking low bids? Are we taking design off the shelf? Are we confusing nuclear plant with chemical plant? Are we doing as much as we can to achieve a reliable system?

I inspected the space industry during the last year as well as production of nuclear weapons and some of the aeronautics industry. I find there is a well-developed reliability technology in use. Why are we able to succeed in putting men on the moon and having communication satellites working the first time? How many reactors worked out the first time? How many air cleaning systems worked out the first time? So I leave you with this plea: Not standardization just for sake of standardization. Standardization is useful for saving time but should not interfere with a philosophy or policy that prevents innovation to produce a better mousetrap.