

24th DOE/NRC NUCLEAR AIR CLEANING AND TREATMENT CONFERENCE

DEVELOPMENT OF AN AIR CLEANING SYSTEM FOR DISSOLVING HIGH EXPLOSIVES FROM NUCLEAR WARHEADS*

by

W. Bergman, K. Wilson, K. Staggs, and D. Wapman
Lawrence Livermore National Laboratory
Livermore, CA 94550

Abstract

The Department of Energy (DOE) has a major effort underway in dismantling nuclear weapons. In support of this effort we have been developing a workstation for removing the high explosive (HE) from nuclear warheads using hot sprays of dimethyl sulfoxide (DMSO) solvent to dissolve the HE. An important component of the workstation is the air cleaning system that is used to contain DMSO aerosols and vapor and radioactive aerosols.

The air cleaning system consists of a condenser to liquefy the hot DMSO vapor, a demister pad to remove most of the DMSO aerosols, a high efficiency particulate air (HEPA) filter to remove the remaining aerosols, an activated carbon filter to remove the DMSO vapor, and a final HEPA filter to meet the redundancy requirement for HEPA filters in radioactive applications. The demister pad is a 4" thick mat of glass and steel fibers and was selected after conducting screening tests on promising candidates. We also conducted screening tests on various activated carbons and found that all had a similar performance. The carbon breakthrough curves were fitted to a modified Wheeler's equation and gave excellent predictions for the effect of different flow rates. After all of the components were assembled, we ran a series of performance tests on the components and system to determine the particle capture efficiency as a function of size for dioctyl sebacate (DOS) and DMSO aerosols using laser particle counters and filter samples. The pad had an efficiency greater than 99% for 0.1 μm DMSO particles. Test results on the prototype carbon filter showed only 70% efficiency, instead of the 99.9% in small scale laboratory tests. Thus further work will be required to develop the prototype carbon filter.

I. Introduction

This study is a continuation of the development previously described of an air cleaning system in support of the DOE nuclear weapons dismantlement program in which hot DMSO sprays are used to dissolve the HE from nuclear warheads.⁽¹⁾ The DMSO spray generates a high concentration of aerosols containing dissolved HE that must be contained and filtered by HEPA filters in the exhaust line to prevent HE or potential radioactive contamination from being released to the

*This work was performed under the auspices of the U.S. Department of Energy by Lawrence Livermore National Laboratory under contract no. W-7405-ENG.45.

24th DOE/NRC NUCLEAR AIR CLEANING AND TREATMENT CONFERENCE

atmosphere. In our previous study, the exhaust from the dissolution workstation was exhausted directly into wooden frame HEPA filters.⁽¹⁾ These HEPA filters showed rapid plugging from the DMSO aerosols and developed leak paths through chemical attack by the DMSO. The exhaust system was criticized by reviewers of the previous paper for not using a demister to remove the bulk of the DMSO mist prior to reaching the HEPA filter. This paper presents the results of our recent efforts to develop a more robust exhaust filtration system for the HE dissolution workstations.

II. Air Cleaning System for the HE Dissolution Workstation

The major components of the air cleaning system for the HE Dissolution Workstation are shown in the schematic in Figure 1. The air cleaning system consists of a condenser to chill and condense the hot DMSO vapor, a demister pad to remove most of the DMSO aerosols, a high efficiency particulate air (HEPA) filter to remove the remaining aerosols, an activated carbon filter to remove the DMSO vapor, and a final HEPA filter to meet the redundancy requirement for HEPA filters in radioactive applications. An inlet valve connected to the workstation is used to vent the workstation chamber with HEPA filtered air.

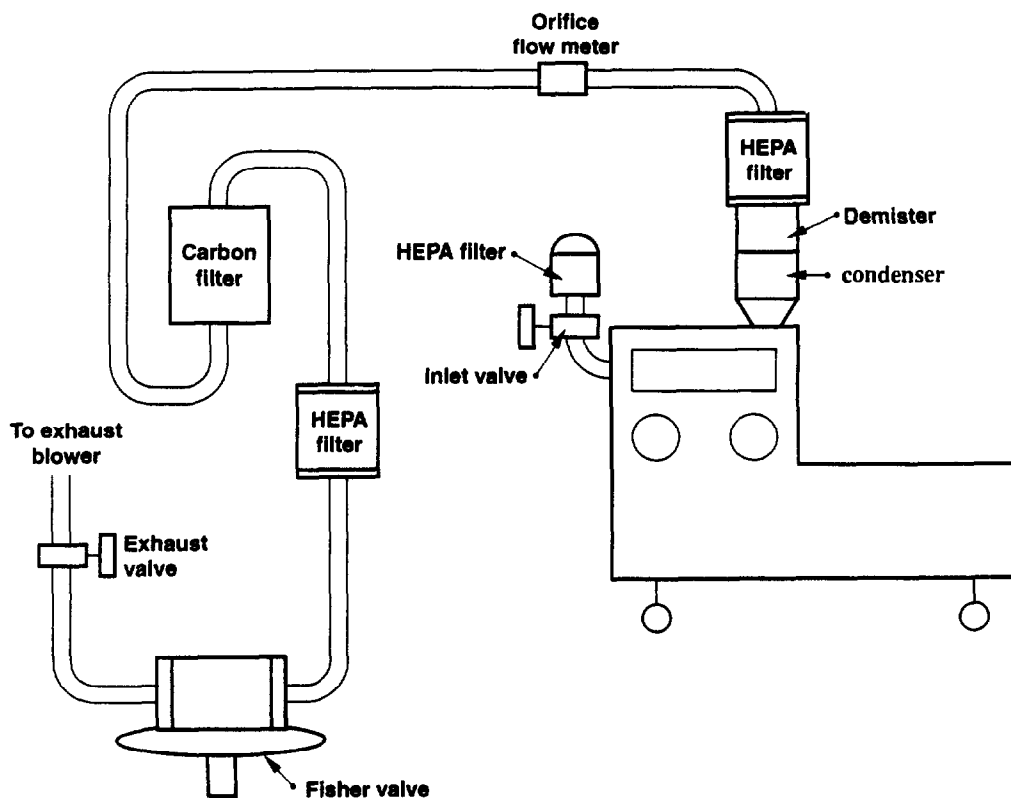

Figure 1 Schematic of exhaust system on the HE dissolution workstation.

24th DOE/NRC NUCLEAR AIR CLEANING AND TREATMENT CONFERENCE

One of the most important safety features of the exhaust system is the Fisher regulator valve. The Fisher valve controls the amount of vacuum applied to the workstation by opening or closing the valve as the workstation vacuum drops below or increases beyond a preset vacuum (usually 1 inch of water) respectively. A vacuum control line (not shown in Figure 1) from the workstation to the diaphragm of the Fisher valve controls the opening of the valve. Maintaining a negative pressure within the workstation insures that the contaminants do not leak out into the workplace. When the inlet valve to the workstation is closed, the building exhaust blower pulls an increasing vacuum on the workstation until the Fisher valve is nearly closed. The Fisher valve is still cracked slightly open to draw a small flow through the workstation due to unintentional leaks in the workstation and components of the exhaust system. Generally this flow is about 1 cfm. The leak flow should be minimized to avoid drawing an excessive amount of DMSO aerosol and vapor through the exhaust system.

In addition to controlling the workstation vacuum during normal operations, the Fisher valve also provides a rapid exhaust flow under accident conditions when the workstation barrier is breached. The most likely scenario for a breached barrier is the loss of a glove. Under this condition, the workstation vacuum drops to nearly 0 vacuum (atmospheric pressure), and the Fisher valve opens fully. This pulls the maximum air flow from the workstation into the exhaust. The exhaust system was designed with minimal restriction to this flow.

A photograph of the front side of the HE Dissolution Workstation is shown in Figure 2. The heated DMSO reservoir and the pump for the DMSO spray are located in the lower, covered portion of the workstation. Hot water is used to heat the DMSO liquid to 150-155 °F by means of a heat exchanger also located in the lower part of the workstation. The dissolution is performed in the 18 ft³ chamber having glove ports and a viewing window. An access door on the right side of glove ports is used to install and remove the HE assembly. The exhaust condenser, demister and first HEPA filter are mounted directly on the roof of the workstation. Condensate from the condenser and the demister can freely drip back into the workstation. The carbon filter, second HEPA filter, Fisher valve, and exhaust valve are mounted on the rack to the left of the workstation.

Figure 3 shows the side view of the workstation as well as the exhaust rack on the right. The cover plate to the side access door is clearly visible. The access door is opened and closed by using a turn screw to slide the access door along tracks. The exhaust train consisting of a condenser, demister, and first HEPA filter are seen directly over the access door. The remainder of the exhaust system is mounted in the rack on the right. Note that the rack has a duplicate set of components to accommodate a second workstation. A detailed view of the exhaust rack is shown in the photograph in Figure 4. This figure also shows the inlet valve and HEPA filter leading to the workstation.

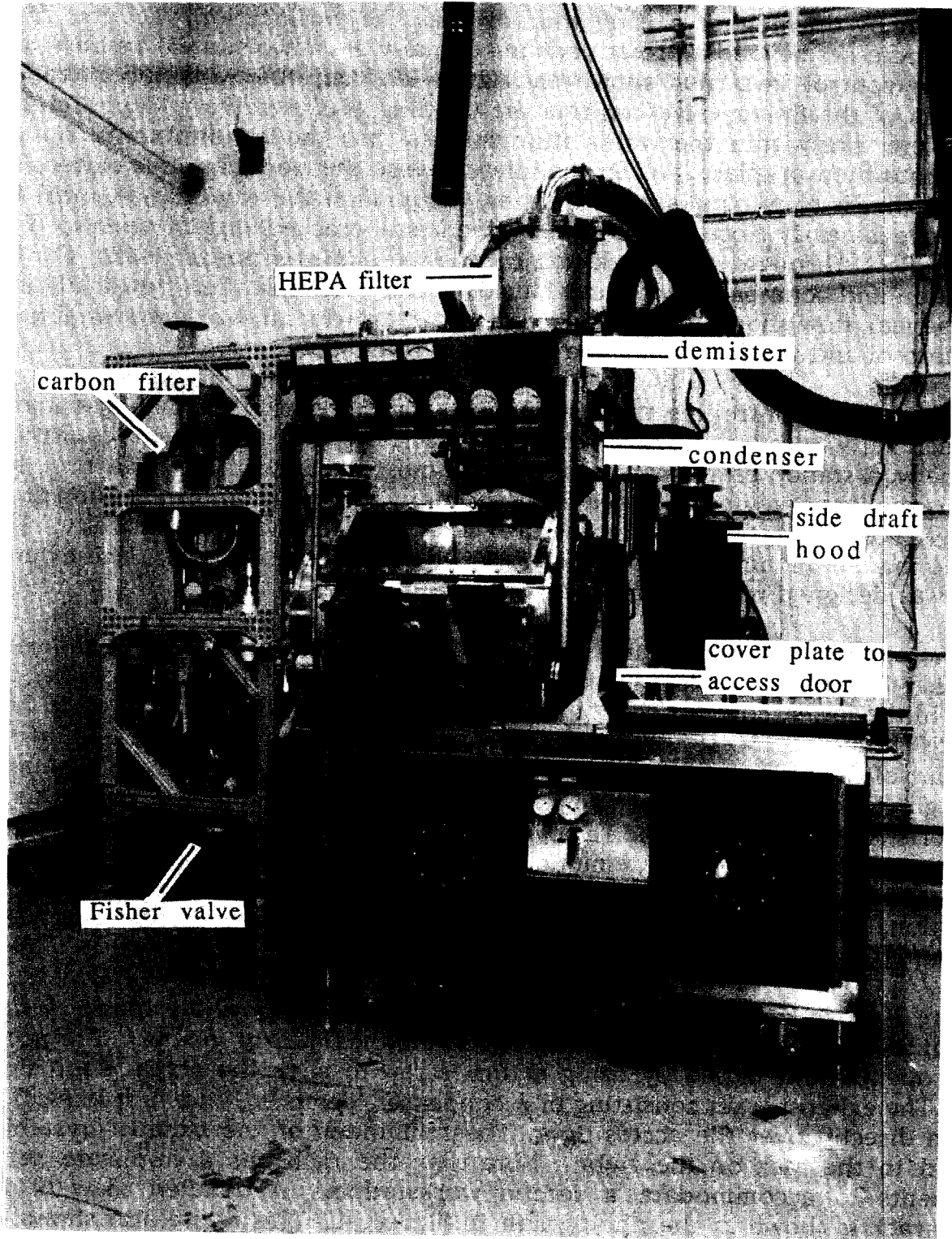

Figure 2. Photograph of the front side of the HE Dissolution Workstation with the exhaust rack on the left side.

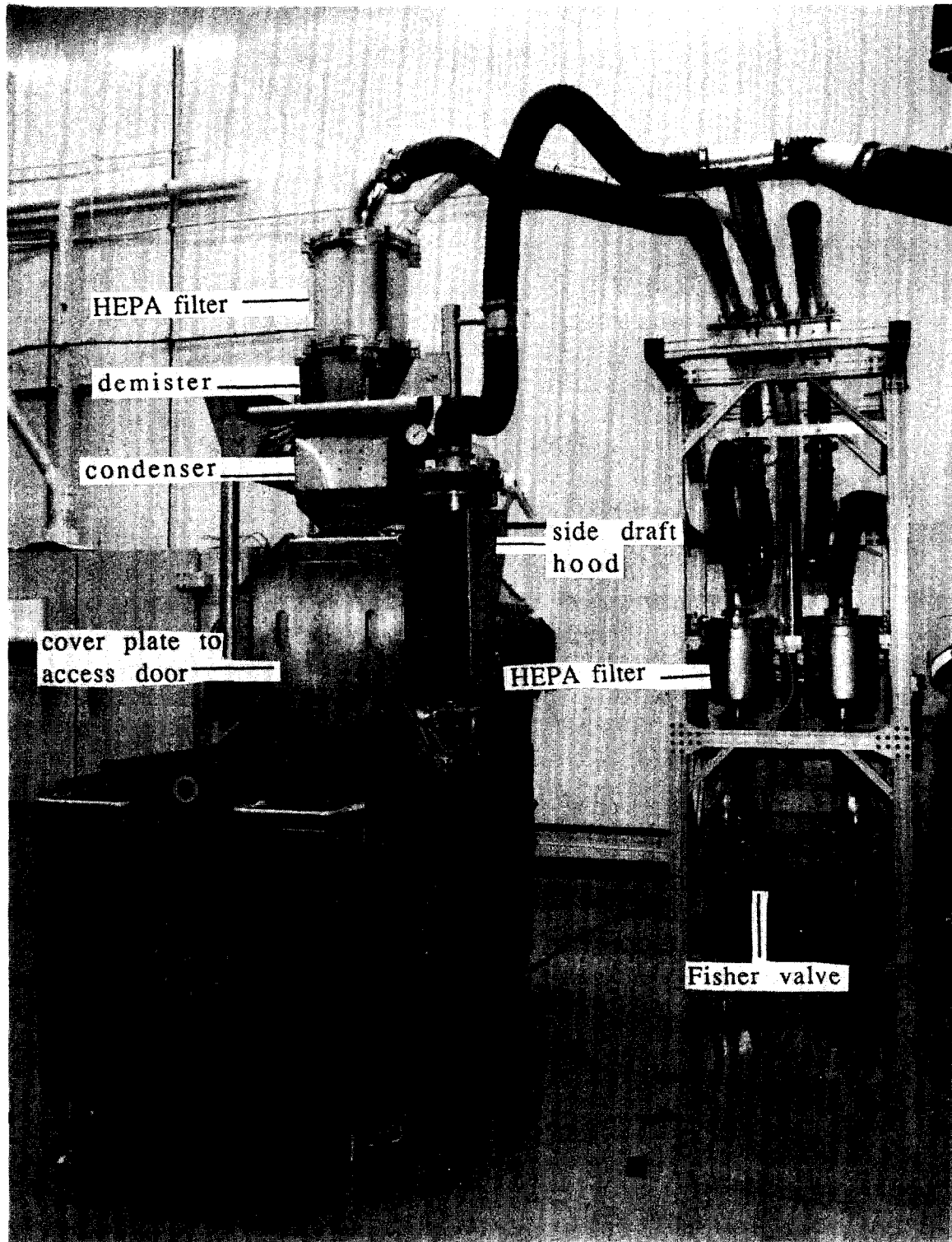

Figure 3. Photograph of the side view of the HE Dissolution Workstation with the exhaust rack shown on the right side. Note that the exhaust rack contains a duplicate set of components for a second workstation.

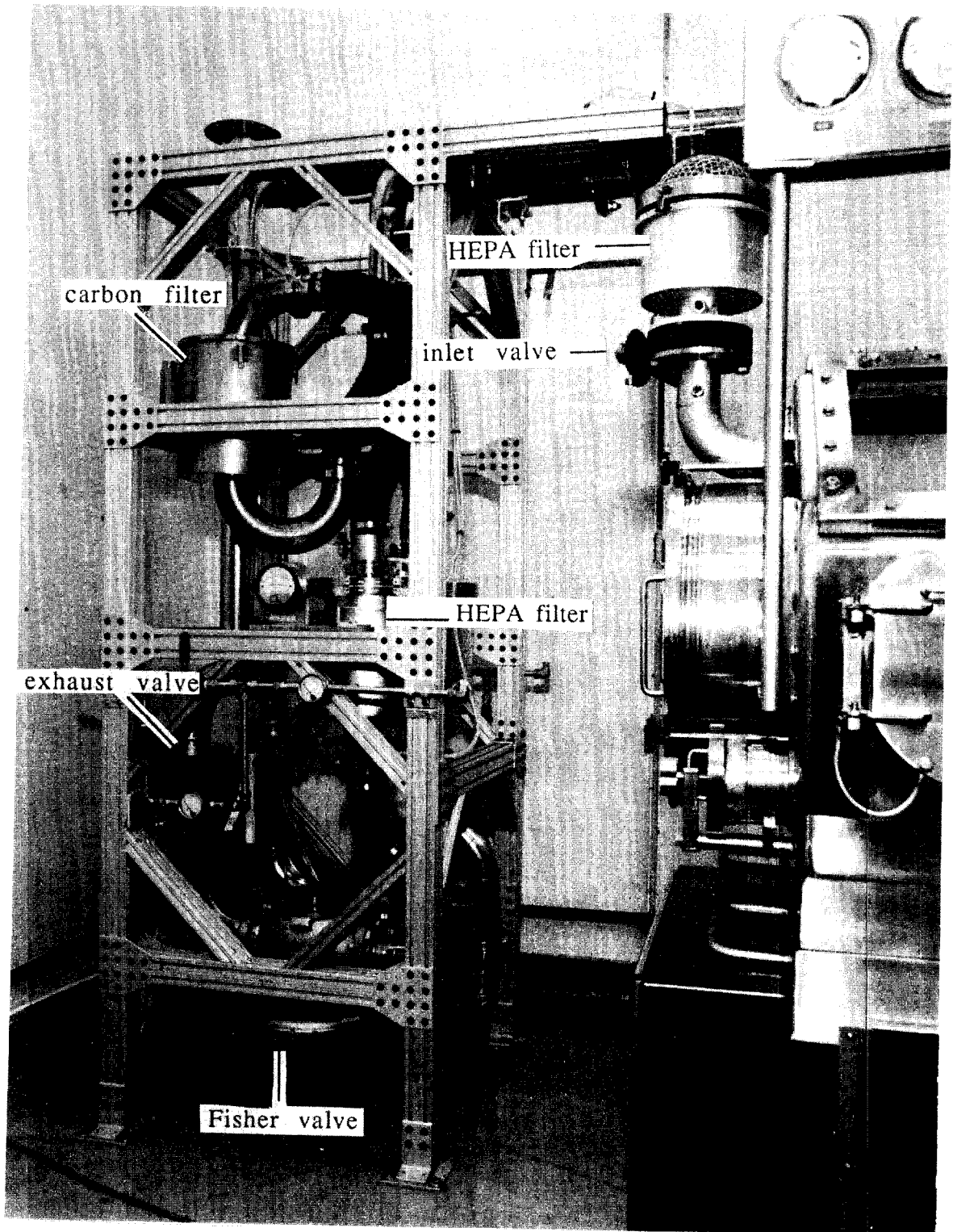

Figure 4. Photograph of the exhaust rack showing the carbon filter, HEPA filter, Fisher valve and exhaust valve. The HEPA filter and inlet valve to the workstation are also seen in this photograph.

24th DOE/NRC NUCLEAR AIR CLEANING AND TREATMENT CONFERENCE

From the point of view of the air cleaning system, the HE dissolution operation can be divided into two phases, a dissolution phase and a venting phase. After the HE assembly is mounted on a fixture and placed inside the workstation, the inlet valve is closed and the hot DMSO spray turned on. In this dissolution phase the workstation is filled with DMSO aerosols and vapor. The only flow through the workstation into the exhaust is due to leaks. When operators need to make adjustments or other operations inside the workstation, the spray is first turned off and the inlet valve opened. This pulls HEPA filtered air through the workstation and sweeps out DMSO aerosols and vapor. The workstation is vented, and personnel are electrically bonded to the workstation prior to entry through the glove ports to prevent the unlikely occurrence of a spark from human electrostatic discharge. This phase of the dissolution operation is the vent phase. The operating parameters during the two phases and during an actual operation are shown in Table 1. We also tabulated some of the measurements made during a preliminary test to demonstrate the actual operation. The exhaust flow and temperatures in the air cleaning system are expected to differ slightly during the venting phase in production operations because the exhaust blowers are stronger than that used in our tests.

Table 1. Operating parameters in the HE Dissolution Workstation (WS).

Parameter	Steady State Simulation		Actual Operation*
	Dissolution	Venting	
Exhaust flow	1 cfm	20 cfm	1-20 cfm
DMSO liquid reservoir temp.	150+/-3 °F	150+/-3 °F	145-155 °F
WS interior air temp.	127+/-5 °F	127+/-5 °F	---
WS exterior surface temp.	107+/-3 °F	107+/-3 °F	---
Condenser inlet temp.	65+/-5 °F	105+/-5 °F	58-107 °F
Condenser exit temp.	44+/- 2 °F	52+/-3 °F	50-56 °F
Demister inlet temp.	44+/- 2 °F	52+/-3 °F	50-56 °F
Demister exit temp.	65+/-3 °F	55+/-3 °F	53-67 °F
HEPA 1 exit temp.	72+/- 2 °F	60+/-3 °F	---

*Note that not all of the temperature measurements were taken during the actual operation. The missing data falls between the 1 and 20 cfm steady state data.

The most significant improvement over the previous exhaust system was the addition of a condenser and demister at the exhaust port.⁽¹⁾ The condenser consists of tightly packed stainless steel tubes in which Fluorinert, FC-77, chilled to 40 °F, flows at 3 gallons/min. We used Fluorinert as the heat exchange medium instead of water because of incompatibility issues with water in case the condenser develops a leak. The 130 °F exhaust, which contains DMSO/HE aerosols and saturated DMSO vapor, is cooled to 50-56 °F under typical conditions. The condenser performance was selected to condense as much of the DMSO vapor as

24th DOE/NRC NUCLEAR AIR CLEANING AND TREATMENT CONFERENCE

possible without causing the DMSO to freeze. Although pure DMSO freezes at 65.4 °F, we did not observe any evidence of freezing, presumably due to the freezing point lowering by the dissolved HE. By condensing out the DMSO vapor into the liquid state, most of the DMSO is removed by the condenser tubes or by the demister. Locating the condenser and demister directly above the workstation allows condensate to drop back into the workstation.

We evaluated how quickly the workstation is vented after the DMSO spray is turned off and the inlet valve opened to establish a time limit before the side access door can be opened to prevent DMSO aerosols from contaminating the workplace. Figure 5 shows the concentration of DMSO aerosols measured in the exhaust of the workstation before the condenser while the inlet vent is open and a constant 20 cfm of air passes through the workstation. Separate measurements were made with the waist and the polar spray manifolds operating normally except for the inlet valve being open. These spray manifolds are two of several different types that are used in the dissolution operation. Figure 5 shows that when the spray is turned off, the aerosol concentration decreases very quickly. After 1 minute, the concentration decreased by about 70%, and after 3 minutes, by 99%. These aerosols have an average diameter of 0.1 μm and behave like gas. Figure 6 shows the same data on a logarithmic scale. The aerosol venting will be much faster in the production operations since the venting flow will be about 30 cfm instead of 20 cfm in our tests.

The release of DMSO vapor from films of hot DMSO on the interior workstation walls, the spray manifold fixture, and the cleaned assembly is expected to be the primary source of DMSO release into the workplace. Allowing the workstation to vent until most of the liquid film is drained and the temperature reduced before the side door is opened will mitigate the release of DMSO vapor. No tests were conducted to establish these time limits. A side draft hood shown in Figures 2 and 3 is intended to mitigate the vapor release when the cleaned assembly is removed from the workstation chamber.

Since we have demonstrated in our previous study that the DMSO sprays are flammable, we set a 1 minute waiting period before workers can work inside the workstation using the butyl rubber gloves after turning off the spray. This time limit was based on computations to establish how quickly the spray droplets would settle out in the workstation. The typical size of the droplets ranged from 107 to 120 μm, based on data from the spray nozzle manufacturer, Bete Fog Nozzle Company (Greenfield, MA). Willeke and Baron showed that the fraction of particles, N , remaining after time, t , is given by ⁽²⁾

$$N = \exp(-V_g t / H) \quad (1)$$

$$V_g = 0.003 \rho_p d_p^2 \quad (2)$$

24th DOE/NRC NUCLEAR AIR CLEANING AND TREATMENT CONFERENCE

- where
- N = fraction of particles of diameter d_p remaining
 - V_g = settling velocity, cm/s
 - t = time, s
 - H = height at the start of settling, cm
 - ρ_p = particle density, g/cc
 - d_p = particle diameter, μm

We used Equations 1 and 2 to compute the settling times for different size DMSO droplets and plotted the results in Figure 7. To be conservative, we assumed that all the droplets were located at the ceiling of the workstation chamber, 3 feet. We see that the spray droplets greater than $50 \mu\text{m}$ will be gone in less than one minute. Since we have shown in a separate study that it is only possible to ignite the DMSO spray droplets and not the small aerosols, waiting for one minute after the spray is turned off will eliminate any potential fire hazard from human electrostatic discharge.⁽³⁾

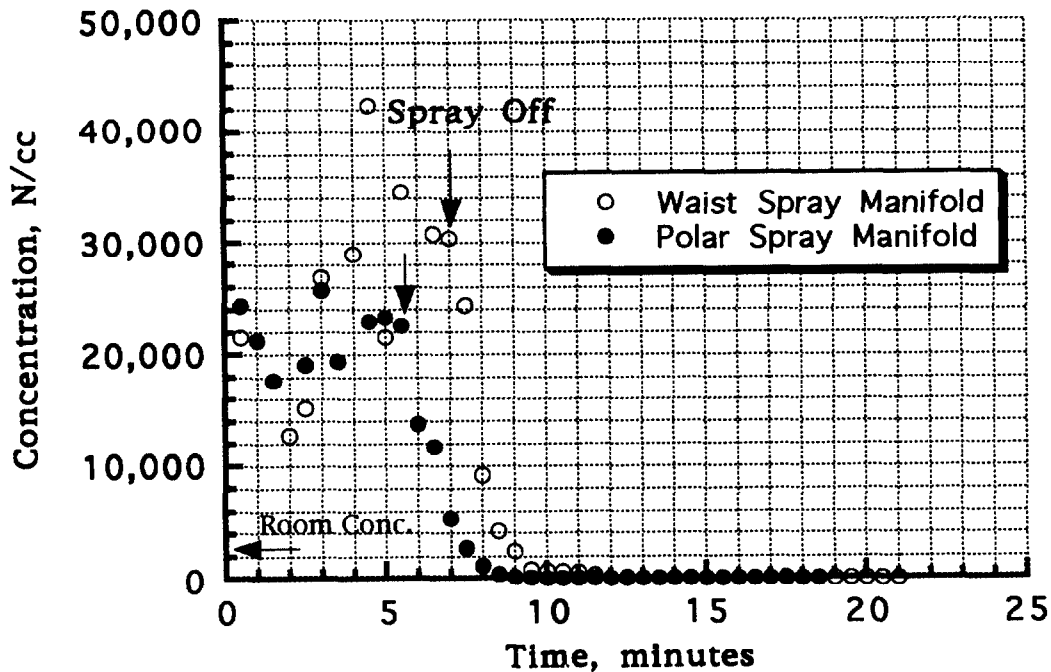

Figure 5. Concentration decay measurements using the polar and waist spray manifolds.

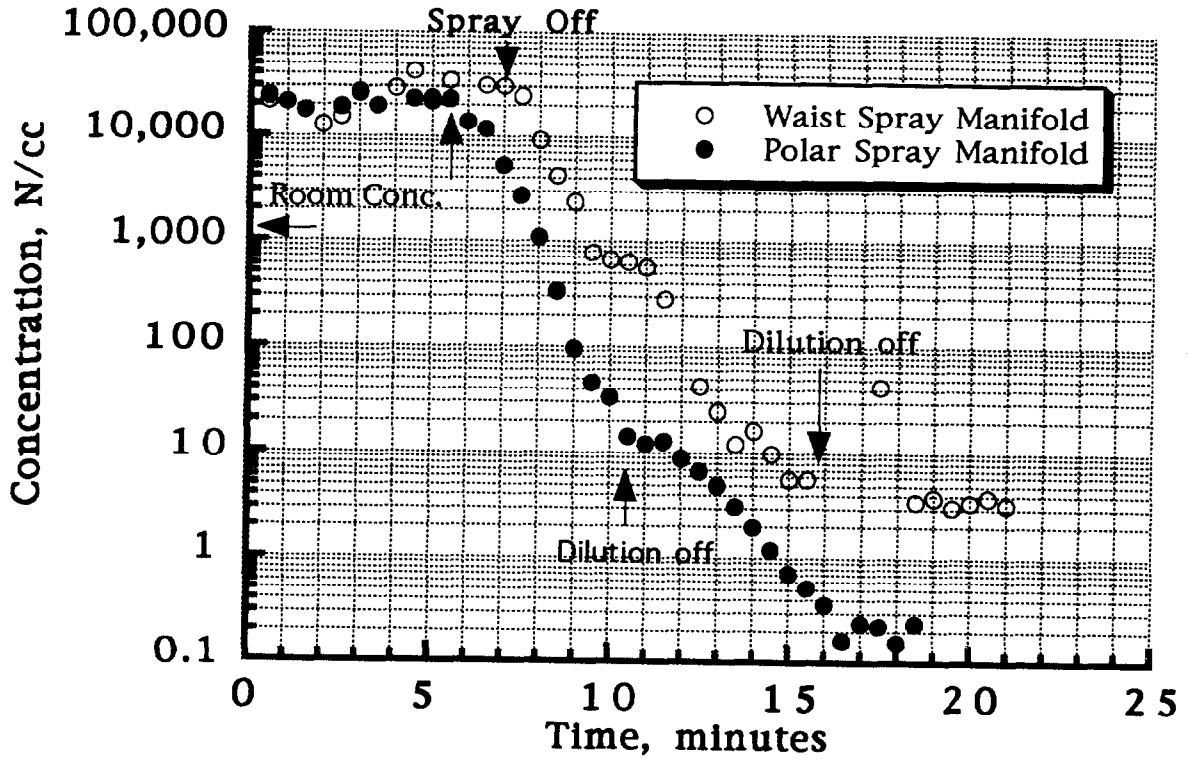

Figure 6. Concentration decay measurements using the polar and waist spray manifolds

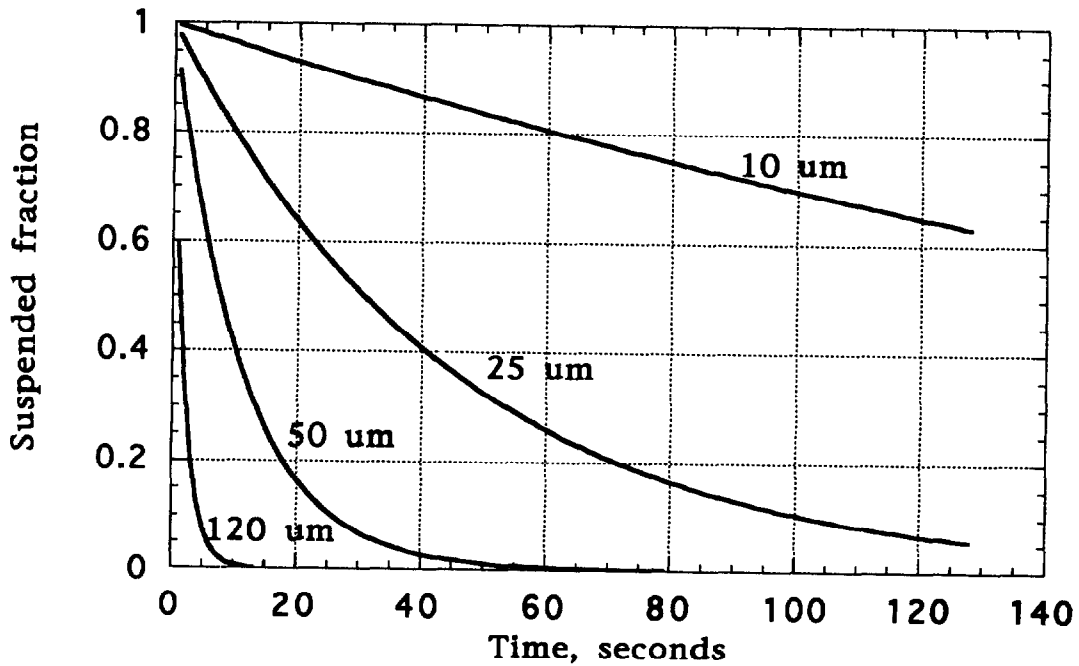

Figure 7. Sedimentation losses as a function of time for different size DMSO droplets.

III. Demister Evaluation

We conducted a series of screening tests to select the most promising demister for use in the air cleaning system. The candidate demisters were chosen based on the performance data provided by the different manufacturers. Most of the standard demisters used in nuclear exhaust systems were not available in smaller sizes and were therefore not evaluated. The most promising demisters were purchased from Amisco (Alvin, TX 77511) and from Coastal Technologies, Inc. (Hampton, SC 29924) and are designated Am and CT respectively. Each of the test samples were 12" x 12" x 4". A description of the different demisters is given in Table 2.

Table 2. Description of selected demisters evaluated in our study.

Demister	Bulk density, lb/cu. ft	Composition	Fiber volume fraction	Fiber Dia. inches
Am GLEC	15	90% 304 ss fiber 10% glass fiber by weight	0.027 ss 0.010 glass 0.037 total	0.011 ss 0.00045 glass
Am 1112	12	304 ss fiber	0.024	0.011
Am 1105	5	304 ss fiber	0.010	0.011
Am 0607	7	304 ss fiber	0.014	0.006
CT 1111	10.8	316 ss fiber	0.022	0.011
CT 911	9	316 ss fiber	0.019	0.011
CT 806	8	316 ss fiber	0.016	0.006

Our screening tests consisted of mounting each demister in a frame and measuring the penetration of DOS aerosols through the demister at 1 and 20 cfm flow rate. Since the demister has a 1 ft² cross-sectional area, the flow velocity through the filter is either 1 or 20 ft/min.. DOS aerosols were generated using the Laskin nozzle generator from the Virtis Co. (Gardiner, NY). We used the Aerodynamic Particle Sizer from TSI (Minneapolis, MN) to measure the DOS particles before and after the demister. The ratio of the downstream to the upstream concentration at each particle size gave the demister penetration at that size. Tables 3 and 4 show the test results for the demister penetration measurements at 1 and 20 cfm respectively.

Table 3. DOS penetration measurements on candidate demisters at 1 cfm.

Demister	DP, in. H ₂ O	DOS Penetration at Indicated Diameter			
		0.5 μm	1.0 μm	2.0 μm	3.0 μm
Am GLEC	0.004	0.33	0.34	0.12	0.05
Am 1112	<0.001	0.95	0.86	0.67	0.38
Am 1105	<0.001	0.91	0.83	0.70	0.45
Am 0607	<0.001	1.00	1.00	0.80	0.60
CT 1111	<0.001	0.88	0.83	0.65	0.48
CT 911	<0.001	0.90	0.85	0.72	0.56
CT 806	<0.001	1.00	0.95	0.88	0.70

24th DOE/NRC NUCLEAR AIR CLEANING AND TREATMENT CONFERENCE

Table 4. DOS penetration measurements on candidate demisters at 20 cfm.

Demister	DP, in. H ₂ O	DOS Penetration at Indicated Diameter			
		0.5 μm	1.0 μm	2.0 μm	3.0 μm
Am GLEC	0.165	0.80	0.65	0.38	0.15
Am 1112	<0.001	0.86	0.85	0.80	0.68
Am 1105	<0.001	1.00	0.98	1.00	0.83
Am 0607	<0.001	0.92	0.92	0.92	0.90
CT 1111	0.002	0.90	0.90	0.90	0.80
CT 911	0.003	0.98	0.94	0.95	0.90
CT 806	0.002	0.95	0.95	0.83	0.60

Based on these screening tests, the best demister for our application was the Amistco GLEC demister. Note that this demister also had significantly higher pressure drop than the other demisters because of the glass fiber blend. We did not evaluate the ease of liquid drainage as part of our screening test because we were primarily concerned with high removal efficiency. In effect, we viewed the demister as a disposable prefilter.

Figure 8 shows a photograph of the GLEC demister pad selected for our study. The demister pad consists of multiple layers of glass fiber cloth with steel fibers interwoven to provide rigidity and some space between the layers. The high collection efficiency and pressure drop for the GLEC demister is due to the small diameter glass fibers (12 μm) that make up the yarn in the cloth layers.

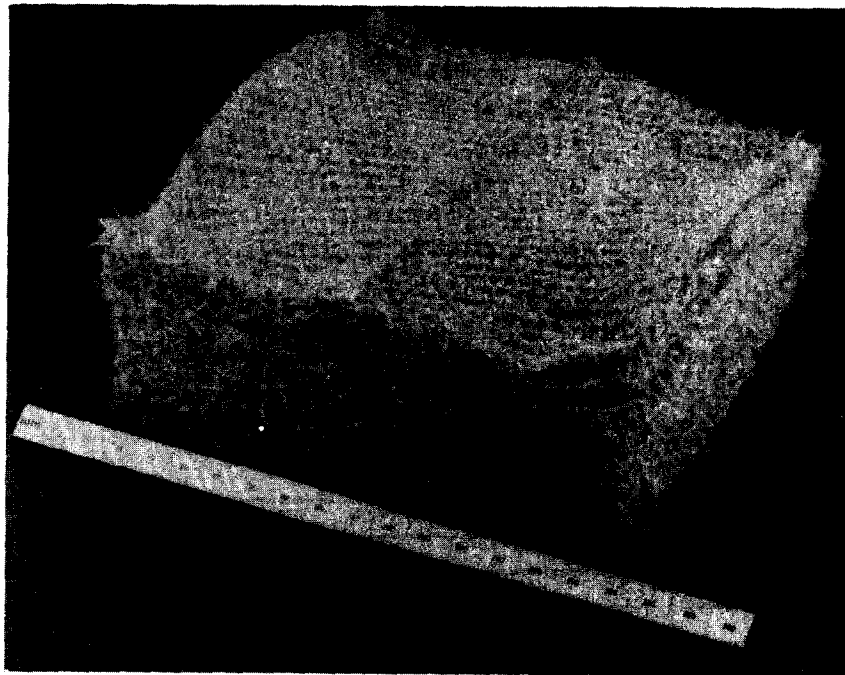

Figure 8. Photograph of the Amistco GLEC glass/steel fiber demister next to 410 mm ruler.

24th DOE/NRC NUCLEAR AIR CLEANING AND TREATMENT CONFERENCE

We then evaluated the performance of the GLEC demister using DOS aerosols at room temperature and DMSO aerosols under actual operating conditions in the HE dissolution workstation. The DOS aerosols were generated using a Laskin nozzle generator and were injected into the workstation. We determined the penetration of DOS aerosols through the demister from the ratio of the downstream to the upstream concentration measurements. We used a LASAIR laser particle counter from Particle Measuring Systems (Boulder, CO) to measure the aerosols.

Figures 9 and 10 show the results of our DOS penetration measurements on two different GLEC demisters at 1 and 20 cfm. Note that the maximum DOS penetration at 1 cfm and 20 cfm occur at about 1.4 μm and 0.5 μm diameter respectively. The aerosol penetration at 20 cfm is also much higher than at 1 cfm. These observations are consistent with filtration theory and demonstrate that diffusional deposition is the primary mechanism responsible for capturing the submicron particles.

We obtained separate measurements with the demister at 70 °F and at 40 °F to determine what effect the temperature would have on the demister performance. The data collected at 40 °F are shown as dark points, whereas the data collected at 70 °F are shown as open points. From Figures 9 and 10, we see that at 20 cfm, the tests at 40 °F showed a higher penetration at the smaller particle sizes than the corresponding tests at 70 °F. This is consistent with the diffusional capture mechanism whereby particles have lower Brownian motion at lower temperatures and consequently are not captured as well as at the higher temperatures. The temperature effect on the aerosol penetration is less noticeable at 1 cfm than at 20 cfm because Brownian capture is already dominant at the low flow rate, and increasing the temperature would not make a large change.

The higher penetration at the 1 cfm flow in Figure 10 compared to the 1 cfm flow in Figure 9 is most likely due to greater leak paths through the demister. It is well established that filters having leaks have much higher penetrations at low flow rates than filters without leaks because of the preferential flow through leaks. The preferential flow through leak paths does not occur at higher flow rates as shown by the same penetration in Figures 9 and 10.

We also measured the penetration of DMSO aerosols through the demister at 1 and 20 cfm under steady state conditions with constant DMSO spraying. Although the DMSO spray normally would be turned off before the inlet valve is opened, we conducted the tests to see if there were any differences in performance between the DMSO and the DOS tests. We also measured the DMSO concentration before the condenser to characterize the challenge DMSO aerosols. Figure 11 shows the results of the DMSO concentration measurements at 1 cfm. An important finding in this figure is that the DMSO challenge aerosols have an average diameter of 0.1 μm . These are extremely small aerosols and generally require high efficiency filters to remove them. Figure 11 also shows the condenser is removing about 50% of the aerosols. This is not surprising considering the thermal gradient that is driving the DMSO aerosols to the cold condensing tubes. A portion of this removal efficiency also may be an artifact of the aerosol measurement. The DMSO

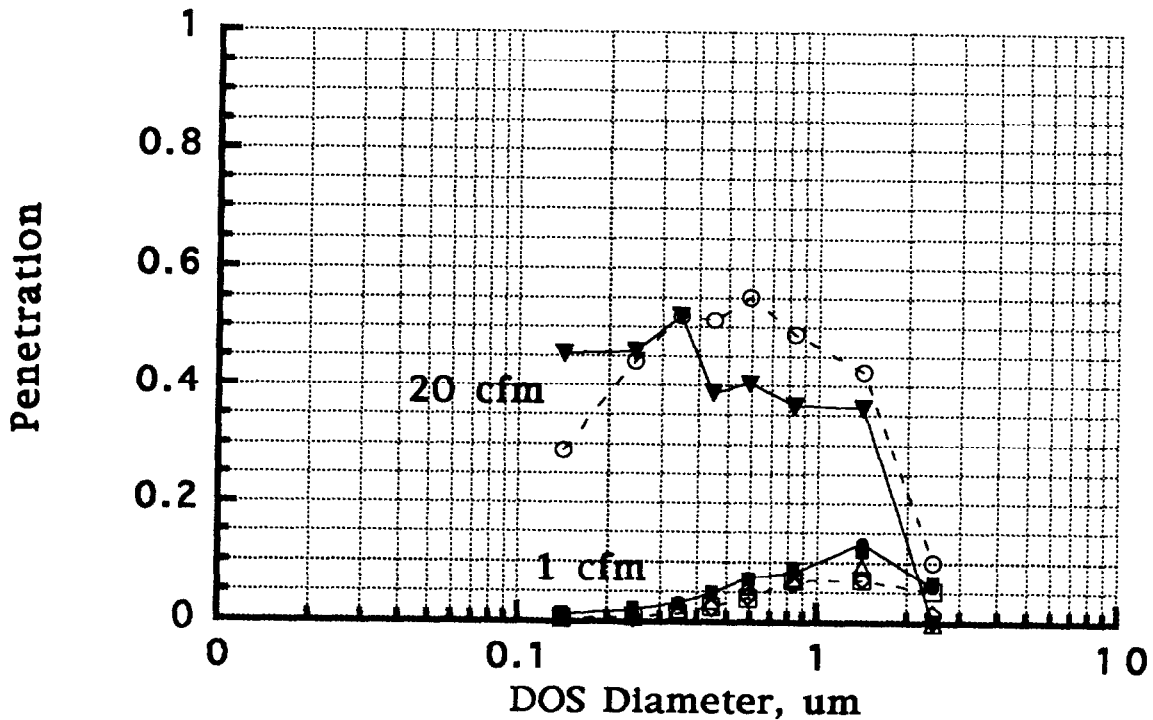

Figure 9. Penetration of DOS aerosols through a demister at 1 and 20 cfm exhaust flow. The open data points were taken at 70 °F. The solid data points were taken at 40 °F.

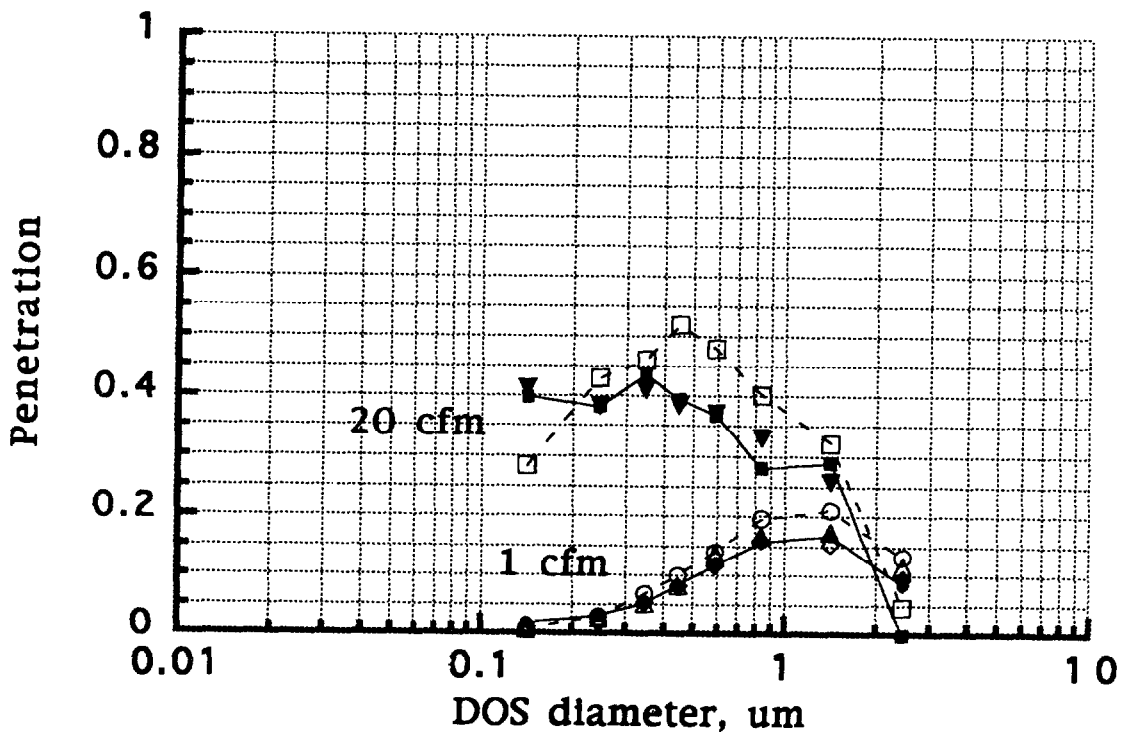

Figure 10. Penetration of DOS aerosols through another demister at 1 and 20 cfm exhaust flow. Open data points were taken at 70 F. Closed data points were taken at 40 F.

24th DOE/NRC NUCLEAR AIR CLEANING AND TREATMENT CONFERENCE

aerosol concentration may have decreased due to evaporation in the diluter prior to the laser counter as the temperature increased from 44 °F at the condenser exit port to 70 °F at the diluter.

However, an unexpected finding in the 1 cfm test is that the aerosol penetration increases with increasing particle diameter until 65% of the particles at 0.3 μm penetrate the demister as shown in Figure 12. We did not have data beyond 0.3 μm because we did not have measurable counts with the 100:1 dilution prior to the laser counter. The DMSO penetration in Figure 12 is in sharp contrast to the DOS penetration in Figures 9 and 10, where the demisters have very low penetration in this size range. We have carefully reviewed the data in Figures 11 and 12 and verified that the results are not due to coincidence counting, a common measurement error. The unexpected results are also not due to Brownian motion effects as previously discussed with the DOS tests. In addition, we were able to repeat the results several times.

We believe that the high penetration with DMSO aerosols is an artifact resulting from a decrease in the pre-demister aerosol concentration due to evaporation as the 44 °F sample is heated to 70 °F in the sampling lines and diluter. The aerosol sample after the demister is only heated from 65 °F to 70 °F in the sampling lines and diluter and therefore would not suffer much evaporation. The disproportionate sample heating before and after the demister is the most probable cause of the unusually high demister penetration in Figure 12.

Anomalies were also found in the DMSO aerosol measurements at 20 cfm. Figure 13 shows the DMSO aerosol concentration measurements taken at 20 cfm before the condenser, before the demister, and after the demister. We see that the concentration of DMSO aerosols has increased significantly after passing through the condenser. This is opposite to what was seen in Figure 11 at 1 cfm. The only explanation is that the saturated DMSO vapor condensed into particles at a faster rate than the DMSO particles were deposited on the cooling tubes. Note in Table 1 that the temperature across the heat exchanger drops 53 °F at 20 cfm and only 21 °F at 1 cfm. The greater temperature drop coupled with the rapid transport through the condenser are the likely reasons for the increase in particle concentration across the condenser. Sampling artifacts due to heating and cooling of the aerosols and the subsequent evaporation and condensation are probably also reflected in Figure 13. Accounting for these effects would increase the difference in aerosol concentration before and after the condenser.

However, the most striking anomaly in the DMSO measurements at 20 cfm is the rapid increase in aerosol penetration with decreasing particle size as shown in Figure 14. Based on the DOS measurements shown in Figures 9 and 10, the aerosol penetration in Figure 14 should decrease with decreasing particle size, not increase. Filtration theory also supports the contention that the Brownian motion will increase with decreasing particle size and therefore result in decreased penetration. We were able to repeat the anomalous results and also verified that the laser counter was not in error due to coincidence counting. As previously

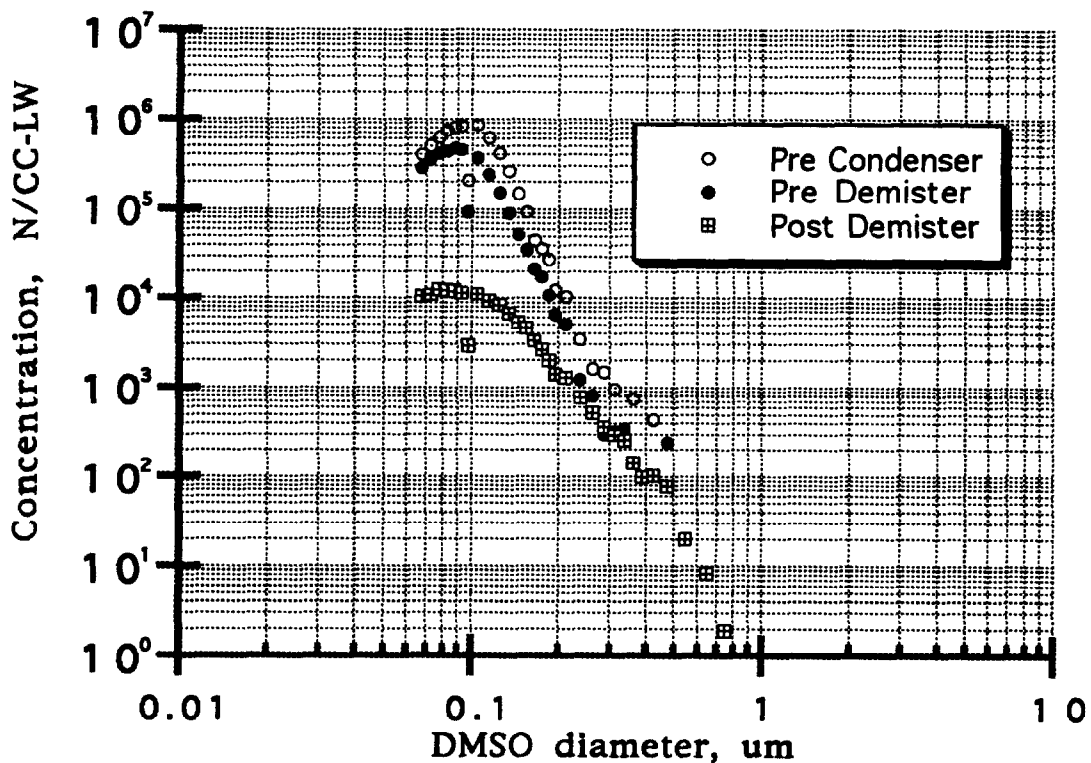

Figure 11. DMSO concentration before the condenser and before and after the demister at 1 cfm exhaust flow.

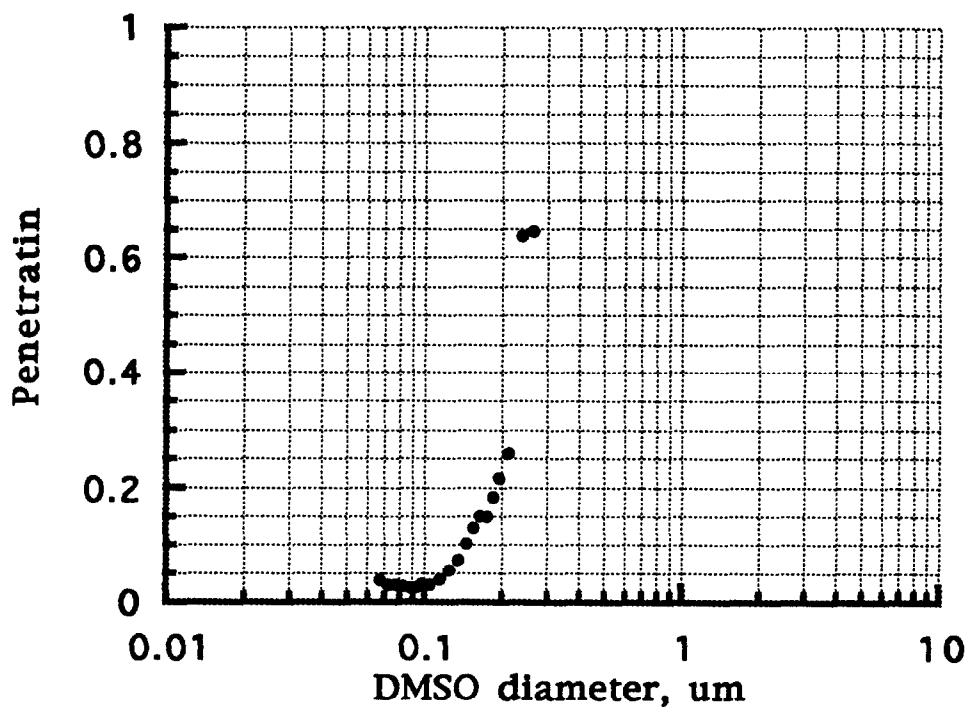

Figure 12. Penetration of DMSO aerosol through the demister at 1 cfm exhaust flow.

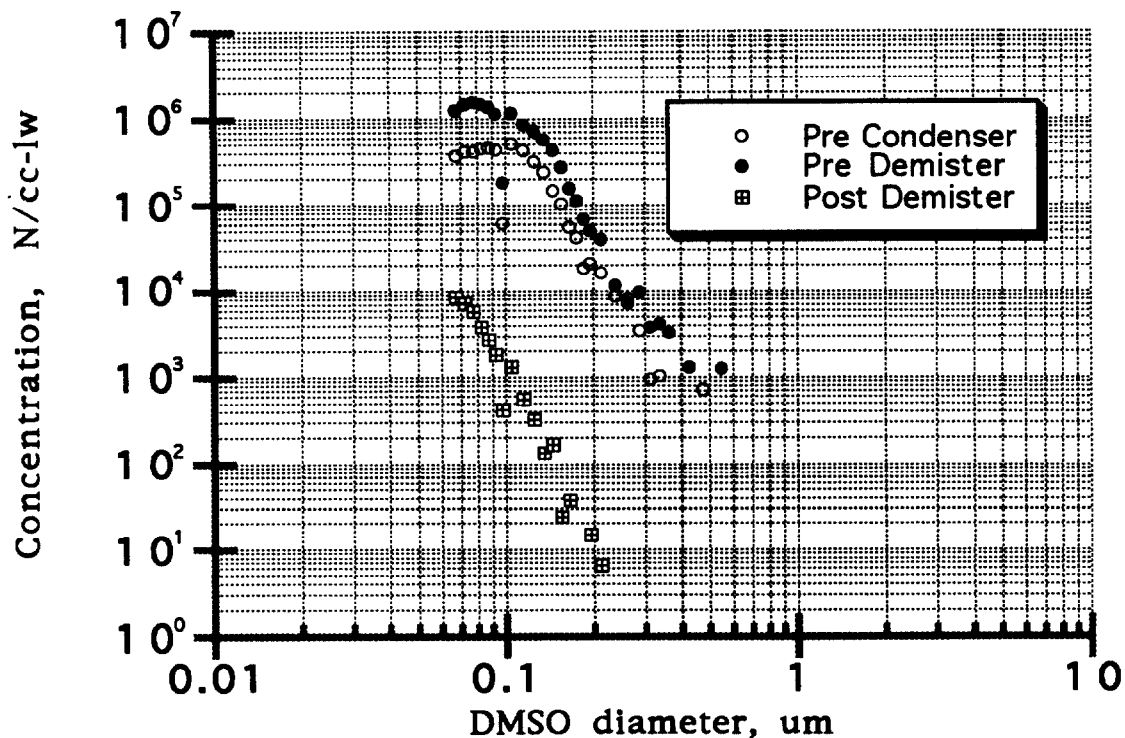

Figure 13. Concentration of DMSO aerosol before the condenser and before and after the demister at 20 cfm exhaust flow.

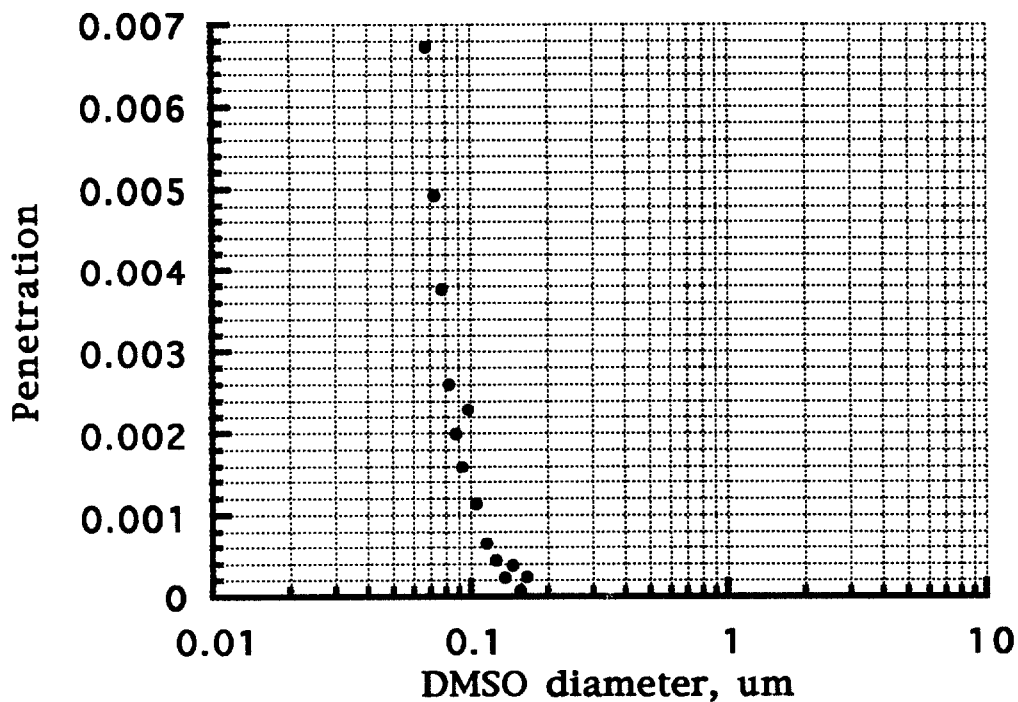

Figure 14. Penetration of DMSO aerosol through the demister at 20 cfm exhaust flow.

24th DOE/NRC NUCLEAR AIR CLEANING AND TREATMENT CONFERENCE

discussed with the 1 cfm data, we believe that the observed penetration curve in Figure 14 is an artifact resulting from changes in concentration due to condensation/evaporation due to temperature changes.

Another observation when comparing the DMSO aerosol penetration in Figure 14 with the DOS aerosol penetration in Figures 9 and 10 is that the demister removes about 100 times more DMSO than DOS. This large difference can only be explained in terms of other processes that are occurring in the demister than classical particle filtration. We can only speculate that DMSO condensation plays a major role in these observations.

In addition to the aerosol measurements with the LASAIR and HSLAS laser counters, we also measured the aerosol concentration using filter samples. Most of our filter measurements were made using MSA HEPA filter cartridges typically used in respirators. In some cases, we also used flat filter media samples. A major problem in all of these measurements was the hygroscopic nature of the DMSO. In our initial filter measurements, we observed a weight loss despite the accumulation of significant DMSO mass. We attributed this loss to the removal of adsorbed water on the filter when filtering DMSO aerosols and vapor. To mitigate this weight loss problem, we preconditioned all filter samples by taking baseline filter samples prior to the actual sample. Another problem with the filter samples was the rapid increase in weight after the filter was removed from the filter holder. To mitigate this problem, we measured the filter weight at periodic intervals (typically 60 seconds) and extrapolated to the time the filter was removed. In some cases, we obtained negative mass measurements as seen in Tables 5 and 7 despite our precautions. For the mass measurements before and after the condenser, the DMSO liquid would condense and accumulate in the filter holder and in the upstream sample line. This weight was measured separately.

Table 5. Concentration measurements of liquid DMSO in the exhaust of the Workstation at 1 cfm.

Location	test	Concentration, g/m ³		
		Total	Aerosol	Condensate
pre-condenser	1	12.78	2.07	10.71
	2	9.16	2.45	6.71
pre-demister	1	2.64	0.54*	2.10
	2	----	0.12,0.11,0.067	----
post-demister	1	----	0.005*, 0.012*	----
	2	----	-0.011,-0.007	----

* Test conducted on a new demister. All other tests conducted on a used demister.

24th DOE/NRC NUCLEAR AIR CLEANING AND TREATMENT CONFERENCE

Using the procedures described, we measured the DMSO mass concentration before the condenser, before the demister and after the demister when the workstation was operated at 1 and 20 cfm under the conditions shown in Table 1. The test results for the 1 and 20 cfm measurements are shown in Tables 5 and 7 respectively. By taking the ratio of the mass measurements before and after the condenser and before and after the demister, we were able to determine the DMSO removal efficiency for the condenser and the demister. The mass removal efficiencies for the 1 and 20 cfm operations are shown in Tables 6 and 8 respectively. We did not compute efficiency values for negative values of the mass concentration.

Table 6. Removal efficiency for liquid DMSO in the exhaust of the Workstation at 1 cfm.

Component	test	Efficiency, %		
		Total	Aerosol	Condensate
condenser	1	79	74	80
	2	----	95,96,97	----
demister	1	----	99, 98	----
	2	----	----	----

Table 7. Concentration measurements of liquid DMSO in the exhaust of the Workstation at 20 cfm.

Location	test	Concentration, g/m3		
		Total	Aerosol	Condensate
pre-condenser	1	11.77	1.81	9.96
	2	----	----	----
pre-demister	1	5.72	1.09	4.63
	2	----	3.62*	----
post-demister	1	----	-0.013	----
	2	----	0.0053*	----

* Test conducted on flat filter sample and may include condensate.

Table 8. Removal efficiency for liquid DMSO in the exhaust of the Workstation at 20 cfm.

Component	test	Efficiency, %		
		Total	Aerosol	Condensate
condenser	1	51	40	54
	2	----	----	----
demister	1	----	----	----
	2	----	99.9	----

24th DOE/NRC NUCLEAR AIR CLEANING AND TREATMENT CONFERENCE

Our measurements based on laser counts and filter weights show the demister has an efficiency greater than 99% for removing 0.1 μm DMSO aerosols. This data is shown in Figures 12 and 14 for the laser counts and in Tables 6 and 8 for the filter weight measurements. The demister also has a relatively high pressure drop due to the higher fiber volume fraction and small diameter glass fibers.

However, we have not demonstrated the ability of the GLEC demister to drain the DMSO liquid. Data collected on the weight gain of the demisters used in our efficiency studies and demonstration tests showed the demister could collect about 1 kg of DMSO when the pressure drop reached our limit of one inch of water at 20 cfm. The weight gains and corresponding pressure drops for 4 GLEC demisters were 1.57 kg at 0.8 inches, 1.17 kg at 1.1 inches, 0.92 kg at 1.1 inches, and 0.55 kg at 0.7 inches. We could not determine the number of dissolution operations per demister because separate tests were not conducted. However, we estimate each demister can be used for about three dissolutions before changing the demister. No further studies were conducted because we decided to replace the demister after each dissolution operation to avoid the possibility of HE accumulation in the demister. Thus, the demister in our air cleaning system is used as a disposable prefilter.

III. Carbon Filter

We developed a carbon filter to remove the DMSO vapor from the Workstation exhaust because commercially available units were either designed for much larger ventilation systems or had excessive pressure drops. The typical ventilation filter had a 2' x 2' cross sectional area and was designed for flow rates of 1,000 cfm or greater. Smaller annular cartridge filters were developed for military vehicle applications but had pressure drops that greatly exceeded the requirement of less than one inch of water at 50 cfm. In addition to the lack of suitable carbon filter units, there also was no information on the performance of carbon filters for removing DMSO vapors. Thus, we had to establish the basic adsorption characteristics in addition to the design parameters to develop the DMSO carbon filter. The initial step was to demonstrate that activated carbon was effective in removing DMSO vapors.

We conducted a survey test of eight different activated carbons to establish that activated carbon is effective in removing DMSO vapors and to identify the best carbon. The test carbons were packed into empty respirator cartridges having a total carbon volume of 112 cc, a diameter of 7.9 cm and a bed depth of 2.3 cm. The cartridges were filled with carbon poured through a tube having multiple screens and a 2 foot free fall to insure tight packing. Each of the cartridges were weighed before and after the test to establish the weight of the carbon and the weight gain due to adsorbed DMSO vapor. The test consisted of passing 29.4 l/min air containing 500 ppm (1.59×10^{-3} g/l) of DMSO vapor with less than 10% relative humidity at 25 °C through each cartridge. This flow rate corresponded to a flow velocity of 6 m/min since the area was 49 cm² (4.9 l/m). The efficiency of DMSO removal was determined by measuring the concentration of DMSO vapor

24th DOE/NRC NUCLEAR AIR CLEANING AND TREATMENT CONFERENCE

before and after the cartridge using a Miran infrared analyzer (Foxborough Inc.). Since each of the tests were conducted until the carbon was saturated and had 0% efficiency, the increase in carbon weight represented the dynamic adsorption capacity of the carbon for DMSO.

Figure 15 shows the DMSO removal efficiency for each of the eight carbon canisters as a function of exposure time. All of the carbons have similar DMSO adsorption properties. However, sample G215 from PICA USA Inc. (Columbus, OH) had a slightly better performance than the other samples and was therefore selected for the carbon filter in our project. The carbon weight, adsorbed DMSO weight, and the pressure drop for each of the canisters is shown in Table 9.

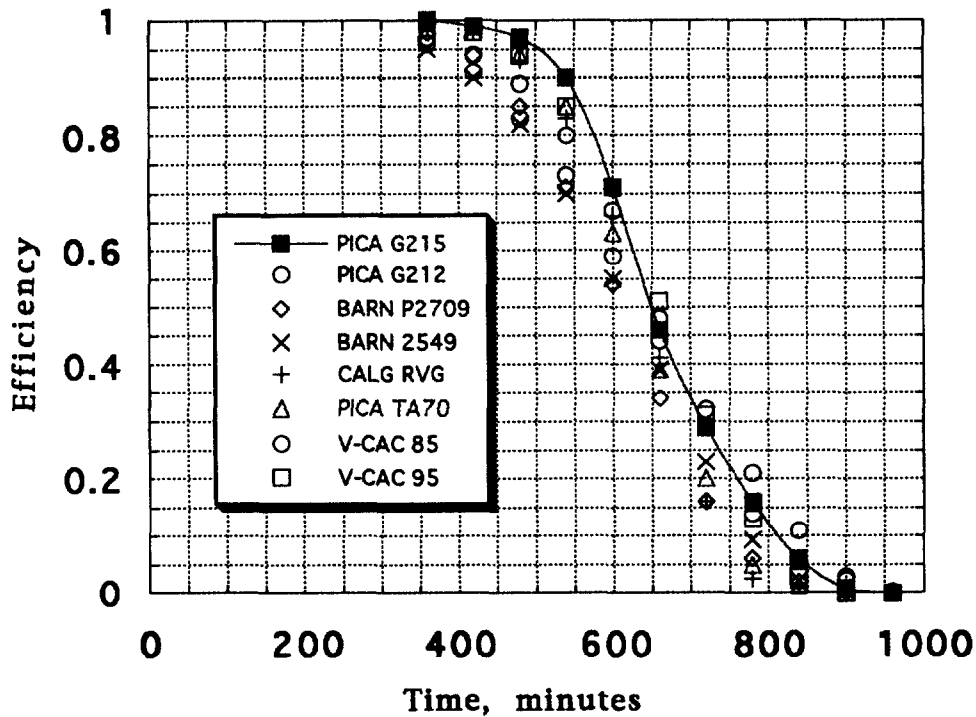

Figure 15 . Survey of carbon capacities plotted as efficiency versus exposure time at 6m/min flow velocity.

Table 9. Experimental measurements of carbon cartridge samples in screening tests at 6 m/min.

Sample	Carbon Weight, g	DMSO Adsorbed, g	Pressure Drop, in. H ₂ O
PICA G215	45.9	31.6	0.31
PICA G212	42.6	31.3	0.21
BARN P2709	55.2	29.7	0.27
BARN 2549	47.7	30.4	0.20
CALG RVG	51.7	30.9	9.31
PICA TA70	51.1	30.6	0.30
V-CAC 85	44.3	31.9	0.29
V-CAC 95	45.8	32.5	0.31

24th DOE/NRC NUCLEAR AIR CLEANING AND TREATMENT CONFERENCE

We then conducted additional tests on new cartridges of PICA G215 at 14.7 and 43.9 l/min flow rates, which correspond to flow velocities of 3 and 12 m/min. These tests were needed to establish the adsorption parameters for the design of the carbon filter. Figure 16 shows the results of the three carbon canisters of PICA G215 tested at 3, 6 and 12 m/min flow velocity. We see that the faster flows results in shorter saturation times. The experimental measurements of the PICA G215 carbon samples are shown in Table 10.

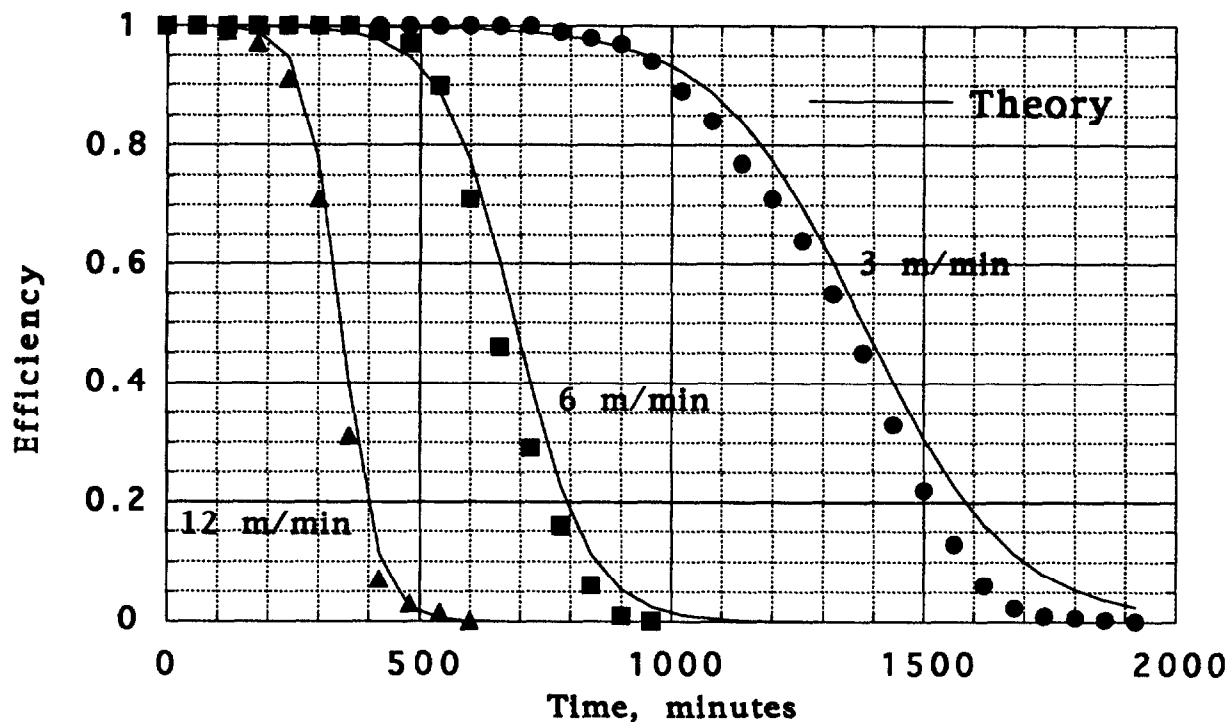

Figure 16. Efficiency of PICA G215 canisters at 3, 6 and 12 m/min flow velocity. Points are experimental data; solid lines represent theory.

Table 10. Experimental measurements of PICA G215 carbon samples in tests at 3, 6 and 12 m/min.

Velocity V m/min	Flow rate, l/min	Pressure drop in. H ₂ O	Carbon Wt W _c , g	DMSO Wt W _a , g	Saturated Capacity W _s = W _a /W _c	Carbon bulk density, ρ _c g/l
3	14.7	0.13	44.0	32.8	0.745	393
6	29.4	0.31	45.9	31.6	0.688	410
12	58.8	0.57	43.9	32.5	0.740	392

In order to design an activated carbon filter for removing DMSO vapor, it was first necessary to determine the adsorption capacity of the selected carbon for DMSO, W_s , and the coefficient, K_v , for the rate of adsorption. Once these two parameters are determined, theoretical equations can be used to determine the key design parameters for the gas filter. The dynamic adsorption capacity, W_s ,

24th DOE/NRC NUCLEAR AIR CLEANING AND TREATMENT CONFERENCE

was experimentally determined and is shown in Table 10. The kinetic coefficient, K_v , characterizing the rate of adsorption is derived from matching experimental data with a theoretical model. We used the modified Wheeler equation, shown in Equation 3 to derive the kinetic coefficient.⁽⁴⁾

$$t = \frac{W_s W_c}{C A V} + \frac{W_s \rho_c}{C K_v} \ln \left[\frac{(1 - E)}{E} \right] \quad (3)$$

where

- A = cartridge area, 4.9 l/m (49 cm²)
- C = DMSO concentration, 1.59 x 10⁻³ g/l (500 ppm)
- E = DMSO removal efficiency
- K_v = kinetic adsorption coefficient, min.⁻¹
- ρ_c = carbon bulk density, g/l
- t = time, minutes
- V = flow velocity, m/min.
- W_c = carbon weight in cartridge, g
- W_a = DMSO weight adsorbed, g
- W_s = DMSO saturated capacity = W_a/W_c , dimensionless

Values of K_v were determined by substituting the parameter values from Table 10 into Equation 3 and fitting each of the three equations to the corresponding efficiency curves in Figure 16. The least squares fits produced K_v values of 1369, 2750 and 4801 min⁻¹ at 3, 6 and 12 m/min flow velocities respectively. To establish the velocity dependence of K_v , we plotted the values of K_v versus the flow velocity in Figure 17.

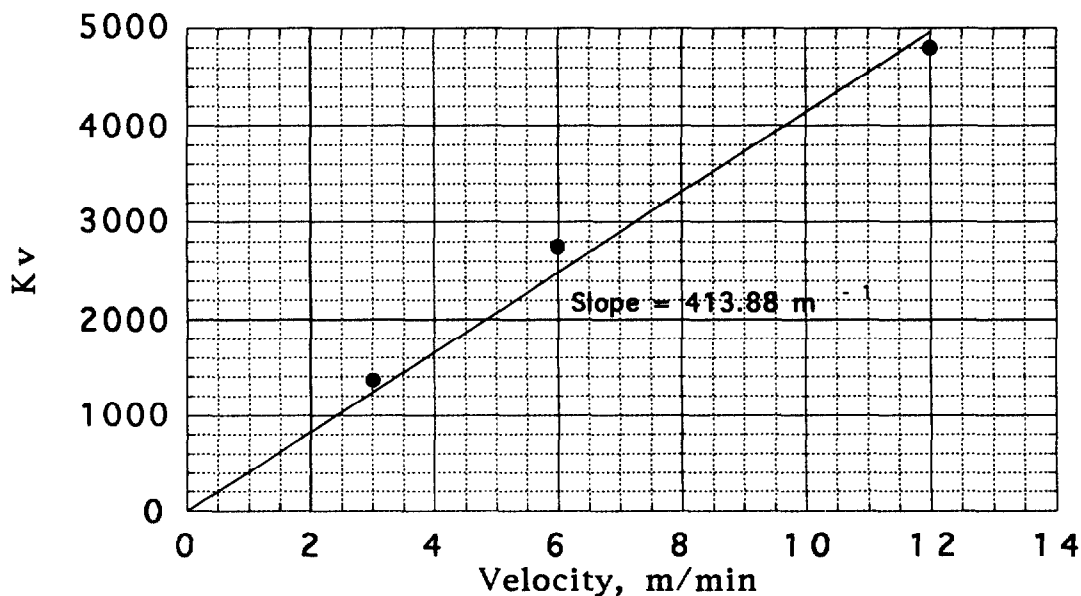

Figure 17 Determination of K_v dependence on velocity.

24th DOE/NRC NUCLEAR AIR CLEANING AND TREATMENT CONFERENCE

From Figure 17, we have

$$K_v = k_v V = 413.88 \text{ V min.}^{-1} \quad (R=0.99035) \quad (4)$$

where the slope, k_v , equals 413.88 m^{-1} . Substituting this expression into Equation 3 yields,

$$t = W_s W_c / (C A V) + W_s \rho_c / (C k_v V) \ln [(1 - E) / E] \quad (5)$$

All of the constants in Equation 5 can be lumped together into constants c_1 and c_2 to yield.

$$t = c_1 / V + (c_2 / V) \ln [(1 - E) / E] \quad (6)$$

Replacing the constants in Equation 6 with the values in Table 10 yields $c_1 = 4207.4, 4053$ and 4169.7 and $c_2 = 444.6, 427.7$ and 439.7 for $V = 3, 6$ and 12 m/min respectively. Averaging these constant values yields

$$t = 4143.4 / V + (437.3 / V) \ln [(1 - E) / E] \quad (7)$$

Equation 7 was used to generate the theoretical curves in Figure 16.

The increasing deviation in Figure 16 between the experimental data and theory at slower velocities is most likely due to the assumption of irreversible adsorption. In practice, the adsorbed DMSO will not be adsorbed irreversibly and will be released, which is more pronounced at longer times and at higher carbon saturation values.

We used Equation 5 and the parameter values determined in the cartridge studies to design the carbon filter for use in the HE Dissolution Workstation. A major constraint on the filter design is the thickness of the carbon bed. Although we used a bed depth of 2.3 cm (0.91 inch) in our screening tests, existing standards on carbon filters require a minimum of 2 inches.^(5,6) This minimum bed depth was established to avoid channeling effects in the ventilation filters. However, since the pressure drop across the filter is directly proportional to the bed depth, it is desirable to minimize the bed depth. Thus, the optimum bed depth that satisfies the current standards and minimizes the pressure drop is 2 inches. To include the effect of carbon bed depth in Equation 5, we made the following two substitutions:

$$Q = A V \quad (8)$$

$$\rho_c = W_c / A T \quad (9)$$

24th DOE/NRC NUCLEAR AIR CLEANING AND TREATMENT CONFERENCE

where, Q = flow rate, l/min.
 T = carbon bed thickness, m

Substituting Equations 8 and 9 into Equation 5 and rearranging yields,

$$t = W_s W_c / (C Q) [1 + (1 / k_v T) \ln [(1 - E) / E]] \quad (10)$$

Equation 10 can be used to establish how much carbon, W_c , should be used for a given set of operating conditions and for a desired filter life, t .

The primary operating conditions are exhaust flow rate, Q , and concentration of DMSO, C . The exhaust flow to be used in Equation 10 is primarily the leak flow in the Workstation during the dissolution operation. We have estimated the leak at 1 cfm based on previous measurements. The only critical leaks are those that allow air into the Workstation during the spraying operation. Leaks occurring in the exhaust system do not increase the DMSO loading on the carbon although they obviously increase the exhaust flow. The increased flow during the venting cycle can be ignored because the box is purged in less than three minutes as shown in Figures 5 and 6.

The DMSO concentration is determined by the air temperature to which the exhaust is cooled. We can assume the DMSO concentration equals the saturated concentration at the demister temperature because the demister removes nearly all of the suspended aerosols, thereby leaving only the saturated vapor to reach the carbon filter. In our application, the typical air temperature within the demister is less than 65 °F, which corresponds to a concentration of 1.6 g/m³.⁽⁷⁾

In our design, we wanted the carbon filter to have a useful life of at least one month of continuous operation. The number of operating minutes in a typical month is 5,160 minutes, assuming 4 hours of dissolution per day and 21.5 days per month. We also assumed the life of the carbon filter was over when the efficiency decreased below 95%.

Substituting these and the other parameter values into Equation 10 yields

$$5,160 \text{ min.} = \{ (0.724) W_c / [(1.6 \times 10^{-3} \text{ g/l})(28.3 \text{ l/min})] \} \times \\ \{ 1 + [1 / (413.9 \text{ m}^{-1})(0.0508 \text{ m})] \ln [(1 - 0.95) / (0.95)] \}$$

Solving this equation yields $W_c = 375 \text{ g}$. Since the average bulk density of the carbon from Table is 398g/l, the minimum volume of carbon for one month operation is 0.95 l or 58 in.³. Dividing this volume by the required 2 inches for the bed thickness yields an area of 29 in.². How this area will be configured into a filter is now a matter of construction considerations. We have selected the cylindrical cartridge design because it is easy to fabricate and to service.

24th DOE/NRC NUCLEAR AIR CLEANING AND TREATMENT CONFERENCE

The cylindrical cartridge filter that we designed is shown in Figure 18, where the cartridge is shown mounted inside a cylindrical housing. The exhaust flows from the bottom port into the interior of the carbon filter, passes through the 2 inch bed and exits around the exterior of the cartridge and finally through the top port. The carbon bed is a 2 inch thick concentric cylinder contained between concentric cylinders made of perforated metal screens that are 12 inches long and have 10 and 6 inch diameters. The net carbon volume of this filter is 9.82 l, which is much larger than the minimum 0.95 l required for one month operation. If the operating assumptions for the HE Dissolution Workstation are correct, then the carbon filter will last for 10.4 months of daily operation before it must be recharged with fresh carbon. Even if the Workstation developed leaks up to 2 cfm, the carbon filter will last for 5.2 months of daily operation.

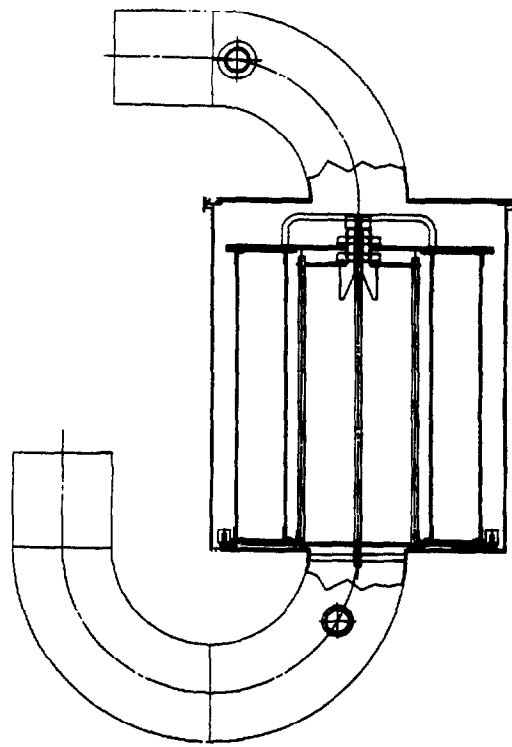

Figure 18. Schematic of cylindrical carbon filter cartridge mounted in a housing.

To prevent the remote possibility of DMSO condensing and collecting inside the carbon filter, we directed the exhaust through a U-tube section before entering the carbon filter. Any DMSO condensate would collect at the low point of the U-tube and can be drained through a plug. It is possible to form DMSO condensate in the lines if the ambient laboratory temperature is lower than the exit temperature of the demister. This can happen if the room heater or if the exhaust condenser do not work properly.

24th DOE/NRC NUCLEAR AIR CLEANING AND TREATMENT CONFERENCE

We have not yet completed developing and testing the carbon filter, but will do so in the near future. A preliminary test during a practice dissolution operation showed the carbon filter was only about 70% efficient. Since the predicted efficiency should be in excess of 99%, additional development is required before the carbon filter is acceptable for use in the HE Dissolution Workstation. One of the leading possibilities for the poor performance is the carbon loading procedure that we used. We filled the annular space with carbon by pouring the carbon granules directly from a container and then shaking the filter unit to insure tight packing. Although we designed a fixture to fill the annular space using gravitational settling, the unit was not available at the time of this report. We plan to complete the loading fixture and correct the low removal efficiency. We also plan to conduct accelerated loading tests on the filter in a similar fashion as seen in Figure 16 for the small test cartridges.

IV. Conclusions

We have developed an air cleaning system for workstations that will be used to remove HE from nuclear warheads using hot sprays of DMSO. The air cleaning system consists of a condenser to cool and condense the hot DMSO vapor, a demister pad to remove most of the DMSO aerosols, a HEPA filter to remove the remaining aerosols, an activated carbon filter to remove the DMSO vapor, and a final HEPA filter to meet the redundancy requirement for HEPA filters in radioactive applications. The demister pad is a 4" thick mat of glass and steel fibers and has an efficiency greater than 99% for 0.1 μm DMSO particles. However, the demister pad is disposed after each dissolution operation to prevent the accumulation of HE. Test results on the prototype carbon filter showed only 70% efficiency instead of the 99.9% in small scale laboratory tests. Thus further work will be required to develop the prototype carbon filter.

V. Acknowledgment

We gratefully acknowledge the help of Messrs. Donald Beason, Scott Doughty, and Ron Arganbright in performing tests on the HE Dissolution Workstation and of Mr. Jeff Oh for designing the exhaust system components. We also thank Mr. Gary Nelson of Miller-Nelson Inc. (Monterey, CA) for performing the carbon canister tests.

VI. References

1. Bergman, W., Wilson, K., Larsen, G., Lopez, R, and LeMay, J., "Degradation of HEPA filters exposed to DMSO" in Proceedings of the 23rd DOE/NRC Nuclear Air Cleaning Conference, Available from NTIS, Springfield, VA, M. First, Ed., CONF-940738, pp. 695-720, (1995).

24th DOE/NRC NUCLEAR AIR CLEANING AND TREATMENT CONFERENCE

2. Willeke, K., and Baron, P.A., "Aerosol Measurement" Van Nostrand Reinhold, New York, (1993).
3. Bergman, W., Staggs, K.J., Turner, D.E., Greenwood, D.W., and Wapman, P.D., "Spark ignition studies of DMSO/HE sprays in the W79 HE Dissolution Workstation" Lawrence Livermore National Laboratory report UCRL-ID-126012, November, (1996).
4. Yoon, Y.H. and Nelson, J.H., "Application of gas adsorption kinetics: A theoretical model for respirator cartridge service life" Am. Ind. Hyg. Assoc. J. 45(8): 509-516 (1984).
5. ASME N509-1989, "Nuclear Power Plant Air-Cleaning Units and Components" American Society of Mechanical Engineers, 345 47th Street, New York, NY 10017, (1989).
6. ASME AG-1-1994, "Code on Nuclear Air and Gas Treatment", American Society of Mechanical Engineers, 345 47th Street, New York, NY 10017, (1994).
7. Martin, D., Hauthal, H.G., and Halberstadt, E.S., "Dimethyl Sulfoxide", Van Nostrand Reinhold Company Ltd., Berkshire, England (1975).

DISCUSSION

BELLAMY: It is interesting to hear about the destruction effort that is underway. There are people worried about nuclear war heads, but it is now more in decontamination and decommissioning activities than in their use.

FLEMING: I was going to suggest that when conducting the filling procedure for the cartridge that perhaps you could take a lesson from the people who fill carbon filters, Fred Leckie will tell you that you need to "triculate" the carbon in to get it to pack efficiently. Perhaps you should talk to a few of the manufacturers to get a good method, because I think that will improve your efficiency dramatically.

BERGMAN: Thank you for your suggestion.

RICKETTS: I was wondering how you actually measured the DMSO concentration up and downstream of your carbon filter?

BERGMAN: We measured DMSO as a relative measurement, based on a Moran analyzer, it was not an absolute measurement. We calibrated the instrument in the laboratory with a known concentration, by injecting it with a syringe, and called that the 100% upstream concentration. Then, for zero percent, we used air filtered through a carbon bed. Although we could do this fairly nicely in the laboratory when we went into the field we did not have the luxury of all these things, and whatever the instrument read at the time, we used. So, it was a relative measurement. We had an upstream zero, and that was the extent of our calibration.

RICKETTS: I understand DMSO is very hygroscopic. Do you have to worry about the concentration of the water vapor in the air stream coming into the system?

BERGMAN: Yes, DMSO is extremely hygroscopic, to the point where we had tremendous experimental problems with things like measuring filter weights. We would load a lot of particles on to a filter, but the filter would lose weight because of losing the previously absorbed water. We had to effectively precondition the filter, i.e., dry it, by passing DMSO vapor through it. It is a tremendously effective water scrubber. For most applications we would have to use an inlet filter to remove water vapor, otherwise we would have a real horrendous problem. Fortunately, the place where these operations will be conducted is in Pantex, which typically has 10% RH, so they do not foresee it as a problem. If there is a problem, you immediately start seeing a lot of high explosives on the bottom of all your trays, not the most optimum condition. When that becomes apparent, you do not proceed very far under those conditions.